

REPORT TO
DEPARTMENT OF STATE GROWTH
MARCH 2017

TIME SENSITIVE FREIGHT

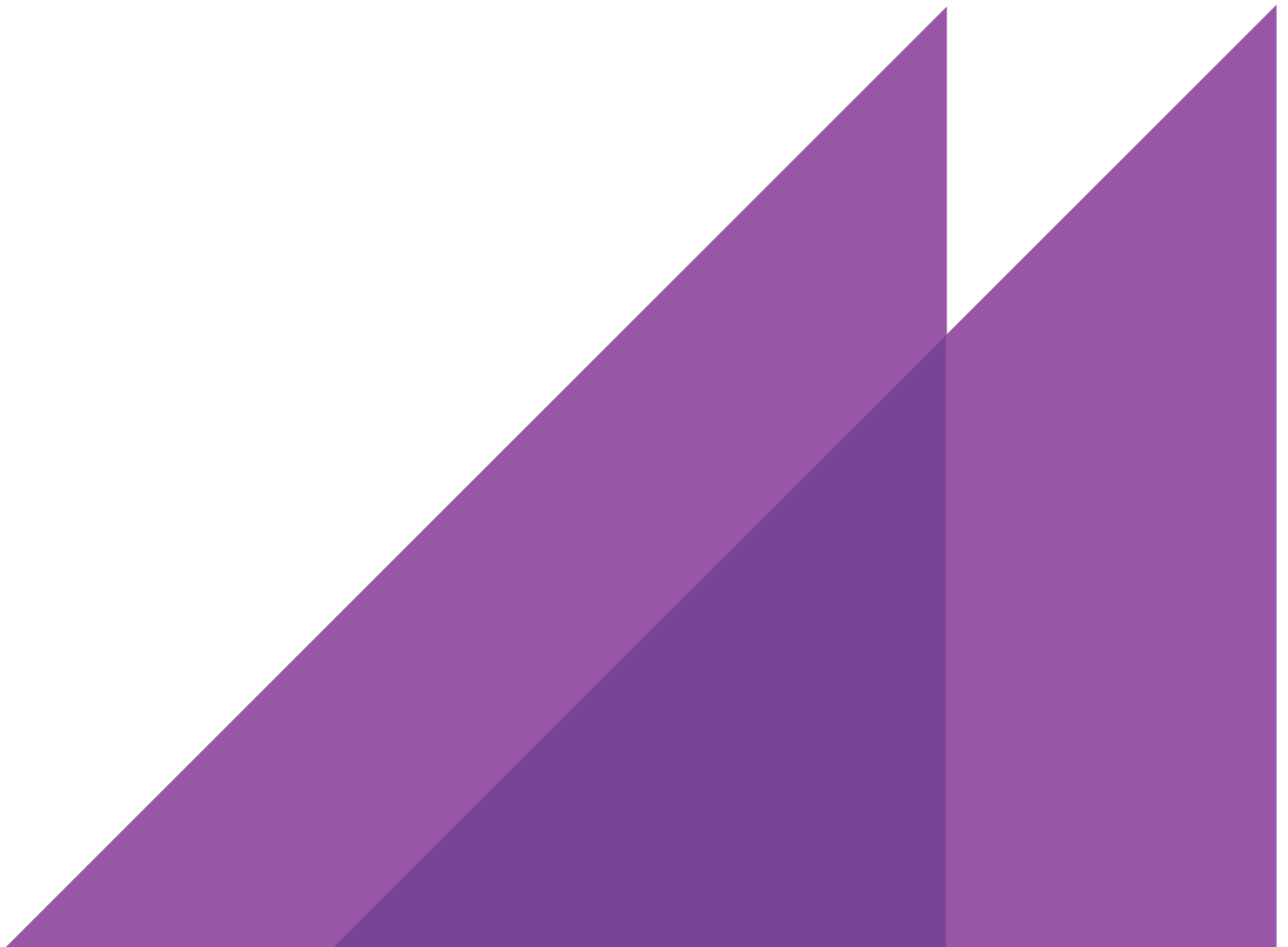

UNDERSTANDING
TASMANIA'S MARKET





ACIL ALLEN CONSULTING PTY LTD
ABN 68 102 652 148

LEVEL FIFTEEN
127 CREEK STREET
BRISBANE QLD 4000
AUSTRALIA
T+61 7 3009 8700
F+61 7 3009 8799

LEVEL ONE
15 LONDON CIRCUIT
CANBERRA ACT 2600
AUSTRALIA
T+61 2 6103 8200
F+61 2 6103 8233

LEVEL NINE
60 COLLINS STREET
MELBOURNE VIC 3000
AUSTRALIA
T+61 3 8650 6000
F+61 3 9654 6363

LEVEL ONE
50 PITT STREET
SYDNEY NSW 2000
AUSTRALIA
T+61 2 8272 5100
F+61 2 9247 2455

LEVEL TWELVE, BGC CENTRE
28 THE ESPLANADE
PERTH WA 6000
AUSTRALIA
T+61 8 9449 9600
F+61 8 9322 3955

161 WAKEFIELD STREET
ADELAIDE SA 5000
AUSTRALIA
T +61 8 8122 4965

ACILALLEN.COM.AU

REPORT PREPARED BY

SIMON SAGERER | YUAN CHOU | ANTONIA HODBY

RELIANCE AND DISCLAIMER THE PROFESSIONAL ANALYSIS AND ADVICE IN THIS REPORT HAS BEEN PREPARED BY ACIL ALLEN CONSULTING FOR THE EXCLUSIVE USE OF THE PARTY OR PARTIES TO WHOM IT IS ADDRESSED (THE ADDRESSEE) AND FOR THE PURPOSES SPECIFIED IN IT. THIS REPORT IS SUPPLIED IN GOOD FAITH AND REFLECTS THE KNOWLEDGE, EXPERTISE AND EXPERIENCE OF THE CONSULTANTS INVOLVED. THE REPORT MUST NOT BE PUBLISHED, QUOTED OR DISSEMINATED TO ANY OTHER PARTY WITHOUT ACIL ALLEN CONSULTING'S PRIOR WRITTEN CONSENT. ACIL ALLEN CONSULTING ACCEPTS NO RESPONSIBILITY WHATSOEVER FOR ANY LOSS OCCASIONED BY ANY PERSON ACTING OR REFRAINING FROM ACTION AS A RESULT OF RELIANCE ON THE REPORT, OTHER THAN THE ADDRESSEE.

IN CONDUCTING THE ANALYSIS IN THIS REPORT ACIL ALLEN CONSULTING HAS ENDEAVOURED TO USE WHAT IT CONSIDERS IS THE BEST INFORMATION AVAILABLE AT THE DATE OF PUBLICATION, INCLUDING INFORMATION SUPPLIED BY THE ADDRESSEE. UNLESS STATED OTHERWISE, ACIL ALLEN CONSULTING DOES NOT WARRANT THE ACCURACY OF ANY FORECAST OR PROJECTION IN THE REPORT. ALTHOUGH ACIL ALLEN CONSULTING EXERCISES REASONABLE CARE WHEN MAKING FORECASTS OR PROJECTIONS, FACTORS IN THE PROCESS, SUCH AS FUTURE MARKET BEHAVIOUR, ARE INHERENTLY UNCERTAIN AND CANNOT BE FORECAST OR PROJECTED RELIABLY.

ACIL ALLEN CONSULTING SHALL NOT BE LIABLE IN RESPECT OF ANY CLAIM ARISING OUT OF THE FAILURE OF A CLIENT INVESTMENT TO PERFORM TO THE ADVANTAGE OF THE CLIENT OR TO THE ADVANTAGE OF THE CLIENT TO THE DEGREE SUGGESTED OR ASSUMED IN ANY ADVICE OR FORECAST GIVEN BY ACIL ALLEN CONSULTING.

© ACIL ALLEN CONSULTING 2017

C O N T E N T S

KEY FINDINGS

V

1

INTRODUCTION

- 1.1 Overview of time sensitive freight in Tasmania
- 1.2 Study objective and scope
- 1.3 Study approach and methodology

1
1
2
2

2

BASE PRODUCTION AND MARKET SEGMENTS

- 2.1 Key data sources and collection process
- 2.2 Risk assessment
- 2.3 Production estimates and seasonality
- 2.4 Market segmentation and overview

4
4
5
5
7

3

GROWTH SCENARIOS AND FREIGHT CONVERSION

- 3.1 Scenario development
- 3.2 Producer aspiration scenario
- 3.3 ABS based high growth scenario
- 3.4 ABS based low growth scenario

10
10
11
16
22

4

TRAILER AND CONTAINER FREIGHT

- 4.1 Freight movements across Bass Strait
- 4.2 Trailer freight – overview of services
- 4.3 Trailer freight – analysis of demand
- 4.4 Trailer freight – analysis of time sensitive freight capacity
- 4.5 Container freight – analysis of demand and capacity

28
28
29
29
32
35

5

AIR FREIGHT

- 5.1 Overview
- 5.2 Key routes
- 5.3 Demand for air freight
- 5.4 Constraints

38
38
39
39
41

6

METHODOLOGY FOR ONGOING DATA COLLECTION

- 6.1 Data Sources
- 6.2 Summary of methodology and recommendations

43
43
45

References

46

C O N T E N T S

FIGURES

FIGURE 1.1	STYLISTED SUPPLY CHAIN OPTIONS	2
FIGURE 1.2	METHODOLOGY OVERVIEW	3
FIGURE 2.1	MARKET SEGMENTS BY LIFE OF PRODUCT	8
FIGURE 3.1	RELATIVE GROWTH BY SCENARIO, 2016 TO 2021	11
FIGURE 3.2	PRODUCER ASPIRATION GROWTH SCENARIO - RELATIVE GROWTH BY SEGMENT, 2016 TO 2021	12
FIGURE 3.3	PRODUCER ASPIRATION GROWTH – PRODUCTION HIGHLY TIME SENSITIVE MARKET SEGMENT	12
FIGURE 3.4	PRODUCER ASPIRATION GROWTH – PRODUCTION TIME SENSITIVE MARKET SEGMENT	13
FIGURE 3.5	PRODUCER ASPIRATION GROWTH – PRODUCTION CUSTOMER INDUCED TIME SENSITIVITY MARKET SEGMENT	15
FIGURE 3.6	ABS BASED HIGH GROWTH SCENARIO - RELATIVE GROWTH BY SEGMENT, 2016 TO 2021	17
FIGURE 3.7	ABS BASED HIGH GROWTH SCENARIO – PRODUCTION HIGHLY TIME SENSITIVE FREIGHT	17
FIGURE 3.8	ABS BASED HIGH GROWTH SCENARIO – PRODUCTION TIME SENSITIVE FREIGHT	19
FIGURE 3.9	ABS BASED HIGH GROWTH SCENARIO – PRODUCTION FREIGHT WITH CUSTOMER INDUCED TIME SENSITIVITY	21
FIGURE 3.10	ABS BASED LOW GROWTH SCENARIO - RELATIVE GROWTH BY SEGMENT, 2016 TO 2021	23
FIGURE 3.11	ABS BASED LOW GROWTH SCENARIO – PRODUCTION HIGHLY TIME SENSITIVE FREIGHT	23
FIGURE 3.12	ABS BASED LOW GROWTH SCENARIO – PRODUCTION TIME SENSITIVE FREIGHT	24
FIGURE 3.13	ABS BASED LOW GROWTH SCENARIO – PRODUCTION FREIGHT WITH CUSTOMER INDUCED TIME SENSITIVITY	26
FIGURE 4.1	TRAILER FREIGHT – DEMAND PROJECTION, PRODUCER ASPIRATION SCENARIO	30
FIGURE 4.2	TRAILER FREIGHT - TRADE WITH PORT OF MELBOURNE BY PRODUCT CATEGORY	31
FIGURE 4.3	TRAILER FREIGHT – MONTHLY EXPORT DEMAND BY PRODUCT GROUP, PRODUCER ASPIRATION GROWTH, 2005 TO 2021	32
FIGURE 4.4	TRAILER FREIGHT - CONSTRAINED DEMAND BY TYPE AND OPERATOR, PRODUCER ASPIRATION GROWTH	33
FIGURE 4.5	TRAILER FREIGHT - CONSTRAINED DEMAND BY TYPE AND OPERATOR, PRODUCER ASPIRATION GROWTH	34
FIGURE 4.6	CONTAINER FREIGHT - DEMAND PROJECTION, PRODUCER ASPIRATION GROWTH SCENARIO	36
FIGURE 4.7	CONTAINER FREIGHT - MONTHLY EXPORT DEMAND BY PRODUCT GROUP AND GROWTH SCENARIO, 2005 TO 2021	36
FIGURE 4.8	CONTAINER FREIGHT - CONSTRAINED DEMAND BY TYPE AND FERRY, HIGH GROWTH	37
FIGURE 5.1	AIR FREIGHT – DEMAND PROJECTION, PRODUCER ASPIRATION GROWTH SCENARIO	41
FIGURE 5.2	AIR FREIGHT - CONSTRAINED DEMAND BY PLANE TYPE, HIGH GROWTH	42

TABLES

TABLE 2.1	BASE PRODUCTION, PRICE AND KEY PRODUCTION REGION BY PRODUCT	6
TABLE 2.2	TASMANIAN TIME SENSITIVE FREIGHT PRODUCTS BY MARKET SEGMENT	8
TABLE 3.1	PRODUCER ASPIRATION GROWTH – PRODUCTION HIGHLY TIME SENSITIVE FREIGHT	13
TABLE 3.2	PRODUCER ASPIRATION GROWTH – PRODUCTION TIME SENSITIVE MARKET SEGMENT	14
TABLE 3.3	PRODUCER ASPIRATION GROWTH – PRODUCTION CUSTOMER INDUCED TIME SENSITIVITY MARKET SEGMENT	16
TABLE 3.4	ABS BASED HIGH GROWTH SCENARIO – PRODUCTION HIGHLY TIME SENSITIVE FREIGHT	18
TABLE 3.5	ABS BASED HIGH GROWTH SCENARIO – PRODUCTION TIME SENSITIVE MARKET SEGMENT	20
TABLE 3.6	ABS BASED HIGH GROWTH SCENARIO – PRODUCTION CUSTOMER INDUCED TIME SENSITIVITY MARKET SEGMENT	22
TABLE 3.7	ABS BASED LOW GROWTH SCENARIO – PRODUCTION HIGHLY TIME SENSITIVE FREIGHT	24
TABLE 3.8	ABS BASED LOW GROWTH SCENARIO – PRODUCTION TIME SENSITIVE MARKET SEGMENT	25
TABLE 3.9	ABS BASED LOW GROWTH SCENARIO – PRODUCTION CUSTOMER INDUCED TIME SENSITIVITY MARKET SEGMENT	27
TABLE 5.1	AIR FREIGHT - MAIN TYPES OF UNIT LOAD DEVICES	38

C O N T E N T S

TABLE 5.2 AIR FREIGHT – PRODUCT TYPES



KEY FINDINGS

Production and export of time sensitive commodities from Tasmania

- This report estimates that the current total volume of time sensitive freight exported from Tasmania is approximately 772,000 tonnes per annum.
- The average volume of production across the 28 commodities considered in this report is 47,479 tonnes.
- The average weighted export price of these products is \$3.55/kg.
- The 10 most significant time sensitive commodities by production volume are shown in the table below:

Product	Annual production (t)
Milk (excluding cheese)	524,500
Potatoes	400,000
Onions	76,700
Carrots	58,500
Salmon	58,400
Frozen meat	51,600
Cheese	38,000
Fresh meat	33,500
Apples	26,500
Beans	10,500

SOURCE: TASMANIAN INDUSTRY (INTERVIEWS WITH ACIL ALLEN, 2016) AND DEPARTMENT OF PRIMARY INDUSTRIES, PARKS, WATER AND ENVIRONMENT, ABS

- The annual value of the 10 most significant **outbound** time sensitive commodities by volume are shown in the table below:

Product	Outbound volume (TEU)
Potatoes	18,111
Salmon	5,923

Product	Outbound volume (TEU)
Frozen meat	4,471
Onions	3,196
Salads	2,550
Carrots	2,455
Fresh meat	2,236
Beans	2,176
Cheese	1,367
Poppy straw	1,210

SOURCE: TASMANIAN INDUSTRY (INTERVIEWS WITH ACIL ALLEN, 2016) AND DEPARTMENT OF PRIMARY INDUSTRIES, PARKS, WATER AND ENVIRONMENT, ABS

- The time sensitive commodities for which producers have the highest growth expectations over the next five years are shown in the table below:

Product	Compound annual growth rate 2016-17 to 2020-21
Other vegetables	13%
Raspberries	12%
Blackberries	12%
Strawberries	12%
Blueberries	12%
Stonefruit other than cherries	11%
Salmon	10%
Oysters	8%
Other brassica	7%
Broccoli	7%

SOURCE: TASMANIAN INDUSTRY (INTERVIEWS WITH ACIL ALLEN, 2016) AND DEPARTMENT OF PRIMARY INDUSTRIES, PARKS, WATER AND ENVIRONMENT, ABS

The 28 time sensitive commodities analysed in this report are grouped according to their degree of time sensitivity:

- **Highly time sensitive commodities**
 - Products in this segment are highly perishable, with lifespans of only a few days
 - This is the smallest segment, covering abalone and lobster only
 - Production is restricted at around 3,000 tonnes per year
 - Export of these commodities is reliant on air freight
- **Time sensitive commodities**
 - Products in this segment perish within approximately two weeks
 - Approximately 92,000 tonnes of these commodities are produced in the base year 2016-17, potentially growing to 136,000 tonnes in 2020-21
 - Commodities in this segment are blackberries, blueberries, cherries, cheese, cut flowers, milk, mussels, oysters, raspberries, salads, salmon, scallops, stonefruit other than cherries, strawberries and tomatoes
 - The highest volume commodities in this segment are milk (excluding cheese), salmon and salads and the fastest growing commodities are all types of berries, stonefruit other than cherries, and salmon
 - These commodities are typically exported in trailers

- **Customer induced time sensitive commodities**
 - Products in this segment have a product life of 21 days or more, and can typically be stored for several months under the right conditions
 - Approximately 713,000 tonnes of these commodities are produced in the base year 2016-17, potentially growing to 766,000 tonnes in 2020-21
 - Commodities in this segment are apples, beans, broccoli, carrots, fresh meat, frozen meat, milk products (cheese), onions, other brassica, other vegetables, pears, poppies and potatoes
 - The highest volume commodities in this segment are potatoes, onions and carrots and the fastest growing commodities are other vegetables, other brassica and broccoli
 - These commodities are exported in trailers and containers.

Freight forecasts

In this study, freight forecasts were developed for three key scenarios, covering a forecast period of 2016-17 to 2020-21. Freight volume growth of time sensitive commodities, by scenario, are shown below

- **Producer aspiration scenario**
 - Highly time sensitive freight: 3,000 tonnes; no growth forecasted due to catch restrictions
 - Time sensitive freight: from 92,000 tonnes to 136,000 tonnes; average annual (compound) growth rate of 8.1 per cent or total growth of 48 per cent
 - Customer induced time sensitive freight: from 713,000 tonnes to 766,000 tonnes; average annual (compound) growth rate of 1.4 per cent or total growth of 7 per cent
- **ABS based high growth scenario**
 - Highly time sensitive freight: 3,000 tonnes; no growth forecasted due to catch restrictions
 - Time sensitive freight: from 92,000 tonnes to 132,000 tonnes; average annual (compound) growth rate of 7.4 per cent or total growth of 43 per cent
 - Customer induced time sensitive freight: from 713,000 tonnes to 721,000 tonnes; average annual (compound) growth rate of 0.2 per cent or total growth of 1 per cent
- **ABS based low growth scenario**
 - Highly time sensitive freight: 3,000 tonnes; no growth forecasted due to catch restrictions
 - Time sensitive freight: from 92,000 tonnes to 102,000 tonnes; average annual (compound) growth rate of 1.9 per cent or total growth of 10 per cent
 - Customer induced time sensitive freight: from 713,000 tonnes to 623,000 tonnes; average annual (compound) growth rate of -2.7 per cent or total growth of -13 per cent.

Modal analysis

- The analysis indicates that trailerised freight volumes across Bass Strait are growing faster than containerised freight.
- There is some overlap in transport mode used across products. The analysis shows that the following products use trailers, containers or air freight for part or all of their supply chain.

Commodity	Mode(s)
Abalone	Air ex Hobart
Apples	Container
Beans	Trailer; Container
Blackberries	Trailer
Blueberries	Trailer
Broccoli	Trailer; Air ex Melbourne
Carrots	Trailer; Container
Cherries	Trailer; Air ex Melbourne

Commodity	Mode(s)
Cut flowers	Trailer
Fresh meat	Trailer
Frozen meat	Container
Lobster	Air ex Hobart
Milk	Air ex Hobart
Cheese	Trailer; Air ex Melbourne
Mussels	Trailer; Air ex Hobart
Onions	Trailer; Container
Other brassica	Trailer
Other veg	Trailer
Oysters	Trailer; Air ex Hobart
Pears	Trailer
Poppies	Trailer; Air ex Hobart
Potatoes	Container
Raspberries	Trailer
Salads	Trailer
Salmon	Trailer; Air ex Melbourne
Stonefruit other than cherries	Trailer
Strawberries	Trailer
Tomatoes	Trailer

SOURCE: TASMANIAN INDUSTRY (INTERVIEWS WITH ACIL ALLEN, 2016)

- Of the 28 products analysed:
 - 22 use trailerised transport
 - 6 use containers
 - 6 use air freight, direct from Hobart
- Approximately 30 per cent of trailerised freight across Bass Strait is associated with agricultural products (excluding livestock).
- For trailers, under the Producer Aspiration Scenario:
 - Time sensitive freight grows to a monthly peak of 1,700 TEU by January 2021. The key driver of growth in this segment is salmon.
 - Customer induced time sensitive freight reaches a peak volume of around 1,300 TEU.
- For containers, under the Producer Aspiration Scenario, peak demand is projected to reach 2,900 TEU in March 2021.
- Between Bass Strait transport operators, there is sufficient capacity to meet forecast trailer and container demand, particularly given planned investment in larger vessels by Toll and SeaRoad.
 - While a continued customer preference to use TT-Line will result in capacity constraints in the trailer market during peak periods, it is likely that SeaRoad's new vessels will attract additional trailerised freight. This analysis modelled one possible capacity scenario where SeaRoad attracts an additional 10 per cent of trailerised freight, which is sufficient to absorb excess peak demand.
 - No constraints are expected in the container freight market.
- Currently, six products use air freight direct from Tasmania: abalone, lobsters, oysters, mussels, poppies and milk. Another four products use air freight from Melbourne.
- For airfreight ex Tasmania, under the Producer Aspiration Scenario, demand is projected to grow to a monthly peak of 1,800 ULD by December 2020. The key driver of growth in this segment are oysters.

- Forecast growth in air freight volumes is limited. Any modal shift from sea to air is also expected to be limited.



ACIL Allen Consulting (ACIL Allen) has been commissioned by the Department of State Growth (the Department) to develop improved information on and understanding of Tasmania's time sensitive freight market.

1.1 Overview of time sensitive freight in Tasmania

The time sensitive freight market relates to goods that have a short shelf life or must travel to meet logistics requirements. In Tasmania, agricultural products dominate this market. Agricultural production is one of the key elements of the Tasmanian economy and accounts for a significant proportion of Tasmania's total freight task by volume. Time sensitive freight has been identified as one of the fastest growing freight types and is projected to grow further due to increasing demand for Tasmanian fresh produce and investment in the industry, such as the Tasmanian Government's recent investment in irrigation.

Freight in Tasmania generally travels from producers and processors to the State's main Burnie to Hobart freight corridor, which connects major population centres at Burnie, Devonport, Launceston and Hobart, together with major export ports and industrial centres. Connections to Bell Bay Port in the north-east and Smithton in the north-west are important freight links. Over 98 per cent of Tasmania's total freight task is moved by sea, with only small volumes air freighted out of Hobart and Launceston airports. The majority of container and trailerised freight is shipped to the Port of Melbourne via Burnie and Devonport Ports. Overnight shipping services are provided by Toll-ANL, SeaRoad Shipping and TT-Line.

Products shipped to the Port of Melbourne are either distributed throughout Australia or transferred to Melbourne Airport for transport to international markets. Small amounts of (highly time sensitive) products are exported from Hobart Airport direct to interstate and overseas destinations. As there is no direct international service from Tasmania yet, these products currently have to transfer in Melbourne before being forwarded to their final destination, which is predominantly in China and South East Asia. From early 2017 onwards, a direct air freighter service between Hobart and Ningbo in China will be operational.

Figure 1.1 illustrates the stylised supply chain options for time sensitive freight produced in Tasmania. Each option begins at a grower from where products travel to a packaging or processing facility. From there, products are either distributed within Tasmania or transported to Melbourne via trailer, container or air, for on-forwarding to interstate or international markets. Trailers are the preferred mode of transport for most time sensitive freight commodities.

While this report presents on-island production volumes, the focus is on time sensitive freight export volumes, i.e. commodities that are exported to interstate and international markets.

FIGURE 1.1 STYLISTED SUPPLY CHAIN OPTIONS

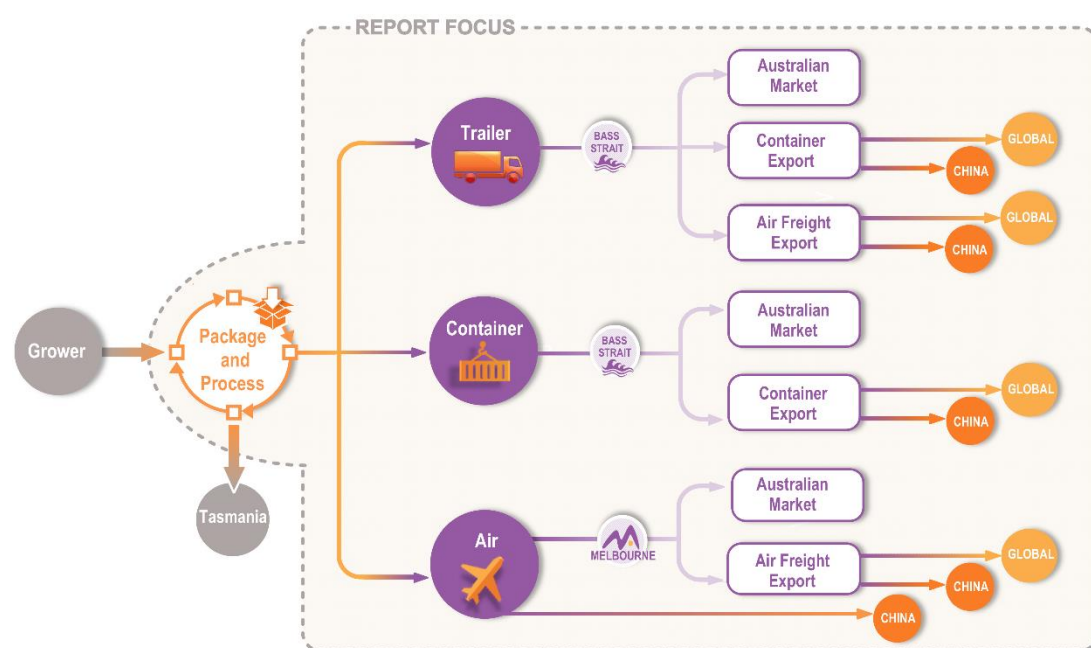

SOURCE: ACIL ALLEN ILLUSTRATION

1.2 Study objective and scope

While some data on time sensitive freight volumes and/or value by key commodity exist, there is no comprehensive picture of the size and value of Tasmania's time sensitive freight market, or future rates of growth. The aim of this study is to assist the Department to identify reliable data sources by commodity, and better understand potential future growth in this market.

The study seeks to:

- Define Tasmania's time sensitive freight market
- Develop growth rates for key market segments and individual commodities, and an aggregate growth rate for the time sensitive freight market
- Develop freight projections under a small number of key scenarios
- Provide expert advice on the development of a repeatable methodology to collect time sensitive freight data.

1.3 Study approach and methodology

To develop an overview of the time sensitive freight market and an understanding of its supply chains, ACIL Allen collated relevant information from existing datasets and supplemented it with information gathered through stakeholder interviews.

The base data presented in this report is not intended to reproduce a single production figure realised under conditions specific to a certain year, but as expected production under average conditions. The year to year uncertainty is covered by conducting a number of scenario analyses. The recommended, ongoing data collection methodology is described in Chapter 6.

A range of stakeholders were consulted as part of this study, covering peak bodies, producers and freight forwarders. The objective of the interviews was to:

- define the time sensitive freight market
- identify the industries that comprise the time sensitive freight market

- locate production, freight and other relevant data
- identify additional key members of the time sensitive freight market supply chain for targeted consultation.

This report supplements information gathered from stakeholders with data from other authoritative sources, including the ABS, Port of Melbourne, and the Tasmanian Government. This data was used to set up a database that characterises the overall time sensitive freight market in Tasmania in terms of:

- key commodities
- supply chain characteristics, including seasonality
- domestic and international markets
- freight volumes.

After establishing this baseline, three growth scenarios were applied to identify likely future freight volumes under different conditions. The forecast period is 2016/17 to 2020/21, beyond which the reliability of any forecasts significantly diminishes. This methodology is illustrated in Figure 1.1.

FIGURE 1.2 METHODOLOGY OVERVIEW

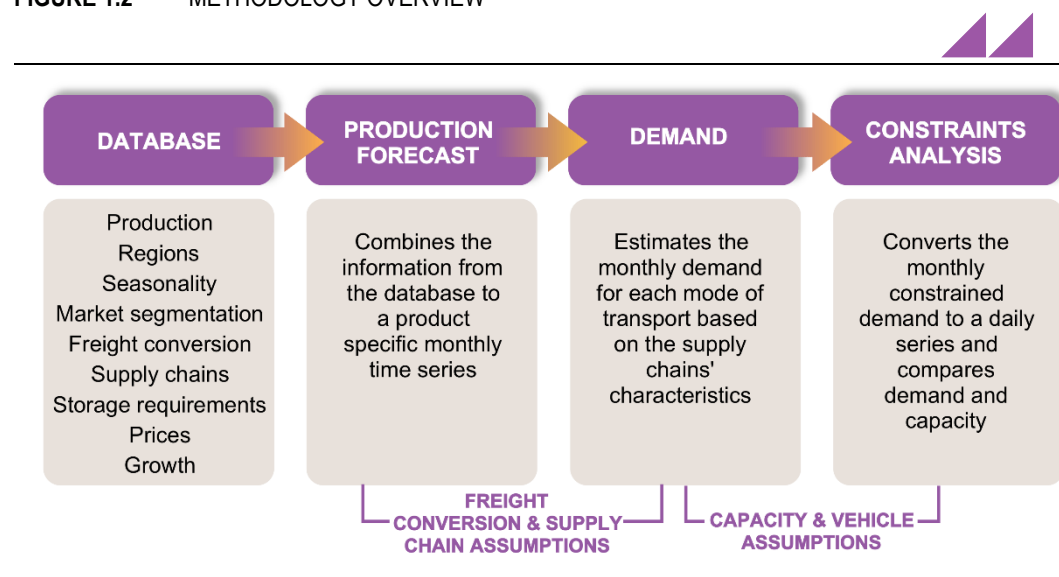



This chapter summarises the data used in this report. It presents the key data sources and the process with which they were augmented to develop base production estimates for time sensitive freight products in Tasmania. It introduces the approach to an assessment of the risk of getting to market on time for each product, and then summarises and analyses key product characteristics.

2.1 Key data sources and collection process

There is currently no existing dataset that comprehensively covers Tasmania's time sensitive freight market. ACIL-Allen has sourced data from a range of sources, including producers and peak bodies, the Australian and Tasmanian Governments, ABS, and the Port of Melbourne. Data reliability across market sectors and commodities varies.

The data presented in this report is not intended to reproduce a single production figure realised under conditions specific to a certain year, but as expected production under average conditions. The year to year uncertainty is covered by conducting a number of scenario analyses.

Data was compiled in two phases. The first established a baseline estimate using publicly available information and some consultation with industry. The second phase reviewed (and corrected) the baseline estimate with further industry consultation and supplemented it with additional desktop research. Industry consultation focused on processors and freight forwarders because they were best able to provide accurate information regarding the supply chain, market share and logistics information. Most processors aggregated product from multiple growers and had a good knowledge of the supply chain.

Small producers or groups of small producers that were not interviewed or for whom production data could not be found are represented by one or more "unspecified producers" with similar base production levels.

The time sensitive freight database compiled in this way contains:

- 264 production estimates defined by the product, producer and supply chains, each containing:
 - annual production
 - seasonality
 - location
 - target market (Tasmania, Australia and export)
- 88 company entries defined by producer and product, each containing:
 - growth expectations
 - market expectations
 - market shares

2.2 Risk assessment

ACIL Allen conducted a high level assessment of the likely risk of a product being unable to arrive at its final destination on time. This assessment is conducted as a multi criteria analysis that assigns scores between 1 (low risk) and 5 (high risk) for five categories to each product. The score bands were derived from the distribution of the observed values, and therefore constitute a measure of the *relative* risk for the assessed product type, compared with all other product types.

The categories are:

- **Seasonality**
Freight forwarders tend to prefer predictably stable demand for their services. This means that when a product is subject to strong seasonality, it might not be allocated a slot if transport capacity is constrained. Anecdotally, seasonal spikes have surprised forwarders at Melbourne Airport and as a result some of the associated freight was left behind. Products with strong seasonal patterns are assigned a high score.
- **Volume**
Higher volume means that a producer can fill a container or trailer more easily and frequently. This tends to increase bargaining power with freight forwarders and might also create risk mitigation opportunities. Products with larger production tonnages are assigned lower scores.
- **Location**
The majority of Tasmania's time sensitive freight is exported by sea through Burnie and Devonport ports, located in the North West. The location risk is based on the expected transit time to these two key ports. The truck journey from the south to these ports can take over five hours. Some of the freight services have relatively early cut off times, making it difficult for some southern producers to harvest and ship on the same day. While it might not be their preferred choice, producers in the north at least theoretically have the option of using one of the earlier vessels. The location risk increases the further south the respective producer's processing facilities are (the only exception being a small number of commodities located in the south, which use air freight).
- **Time sensitivity**
The more time sensitive a product, the quicker it needs to get to market and consequently the number of transport options tends to be more limited. Products with a high degree of time sensitivity (short life) are assigned high scores.
- **Price**
A high price can counteract the risk created by time sensitivity as it allows the producer to utilise faster and more reliable transport options (which are also typically more expensive). For example the product could be flown to market. The price risk score can therefore be used to assess a product's air freight potential: A risk score of one or two makes it a likely candidate for air freight, a score of three a possible candidate and scores of four and five, an unlikely one. Products with a higher price are assigned a lower score.

2.3 Production estimates and seasonality

The base production level for each product type is shown in Table 2.1, together with the corresponding price in Australian dollars per kilogram and the dominant production region. Production volumes and average export prices are sourced from different base years, depending on data availability.

This report assumes annual total milk production in Tasmania of 917,000t (890,000ML), of which approximately 392,500t is processed into 38,000kg cheese, and the remaining 524,500t into milk powders, butter, cream, yoghurts, chocolate, and fresh and long-life milk (the majority of which is milk powder). Demand for milk exports is currently around 10,000t per annum.

Fresh and frozen meat are analysed separately due to a significant difference in their export prices. The milk production volume shown in the table excludes milk diverted for cheese production.

TABLE 2.1 BASE PRODUCTION, PRICE AND KEY PRODUCTION REGION BY PRODUCT

Product	Annual production (t)	Average export price (\$/kg) ^{***}	Approximate export value potential (\$ million)	Dominating production region
Milk	524,500	2.18	1,143	West and North west
Potatoes	400,000	2.75	1,100	West and North west
Onions	76,700	0.54	41	South East
Carrots	58,500	0.89	52	West and North west
Salmon	58,400	10.05	587	Launceston and North East
Frozen meat	51,600	7.34	379	West and North west
Milk products (cheese)	38,000	4.76	181	Hobart
Fresh meat	33,500	16.31	546	Hobart
Apples	26,500	3.45	91	South East
Beans	10,500	7.33	77	South East
Poppy straw	8,300	Not available	Not available	West and North west
Other vegetables	7,400	4.00	30	West and North west
Salads	6,500	5.99	39	West and North west
Cherries	5,000	17.34	87	Hobart
Other brassica	3,800	6.30	24	West and North west
Broccoli	3,400	3.59	12	West and North west
Strawberries	3,300	8.89	29	Hobart
Raspberries	2,400	8.89	21	West and North west
Oysters	2,000	12.60	25	West and North west
Abalone	2,000	60.59	121	West and North west
Blueberries	1,700	8.89	15	West and North west
Pears	1,300	2.83	4	South East
Lobster	1,000	96.31	96	West and North west
Tomatoes	1,000	3.78	4	South East
Mussels	1,000	8.30	8	West and North west
Cut flowers	600	\$35/kg – \$49.50/kg.	Not available	South East

Product	Annual production (t)	Average export price (\$/kg) ^{***}	Approximate export value potential (\$ million)	Dominating production region
Blackberries	400	8.89	4	West and North west
Stonefruit other than cherries	100	6.12	1	West and North west
Total	1,329,400	3.55	4,718	

* No data available

** Milk production excludes milk processed into cheese, which is separately reported in both the table and this report.

*** The export price for berries is based on frozen products. Fresh products attract higher prices.

SOURCE: TASMANIAN INDUSTRY (INTERVIEWS WITH ACIL ALLEN, 2016) AND DEPARTMENT OF PRIMARY INDUSTRIES, PARKS, WATER AND ENVIRONMENT, ABS

In addition to being an important consideration in assessing risk, the export price of a product is a strong predictor of its potential to be carried by air. Prices, as shown in column three of Table 2.1, were gathered from ABS unpublished data, supplied by the Department of Primary Industries, Parks, Water and Environment (DPIPWE). Of note are the export prices for abalone and lobster, which are \$60.59/kg and \$96.31/kg, respectively. These high value products make them likely candidates for airfreight directly out of Tasmania, especially given their highly time sensitive nature. The average export price of products across the 28 considered products (weighted by product volume) is \$3.55/kg.

The average volume of production across the 28 products considered in this report is 47,479 tonnes. The six largest time-sensitive products in Tasmania in terms of production volumes are milk (524,500t), potatoes (400,000t), onions (76,700t), carrots (58,500t), salmon (58,400t) and frozen meat (51,520t). The products of greatest interest in terms of both export volume and value are salmon and frozen meat, as the majority of the fresh milk and vegetables remain in Tasmania for further processing.

Many time sensitive products exhibit a seasonal production pattern. However, this varies between producers and between target markets. For products with a longer shelf life, harvest and export can also have a different pattern.

2.4 Market segmentation and overview

The time sensitive freight market relates to goods that have a short shelf life or must travel to meet logistics requirements. For this report, time sensitive freight relates to fresh and perishable freight that requires a fast or reliable route to market in order to preserve shelf life or meet customer demand. The findings of the stakeholder interviews indicate that the market can be broken down into three segments:

1. **Highly time sensitive freight**
Products in this segment perish within a few days and consequently require very fast routes to market. Production is often very seasonal. This can be driven by demand or harvesting windows. The willingness to pay for these products tends to be high.
2. **Time sensitive freight**
Products in this segment perish within approximately two weeks and consequently require fast routes to market. Production is often seasonal because of harvesting windows.
3. **Customer induced time sensitivity**
Products in this segment have a product life of 21 days or more, and can typically be stored for several months under the right conditions. Since they tend to be delivered to customers on a just in time basis, they require reliable routes to market.

All producers interviewed by ACIL Allen were asked about average product life. Figure 2.1 summarises these results, showing product life in days on the horizontal axis, and the number of producers who indicated that their product fell into that product life category on the vertical axis.

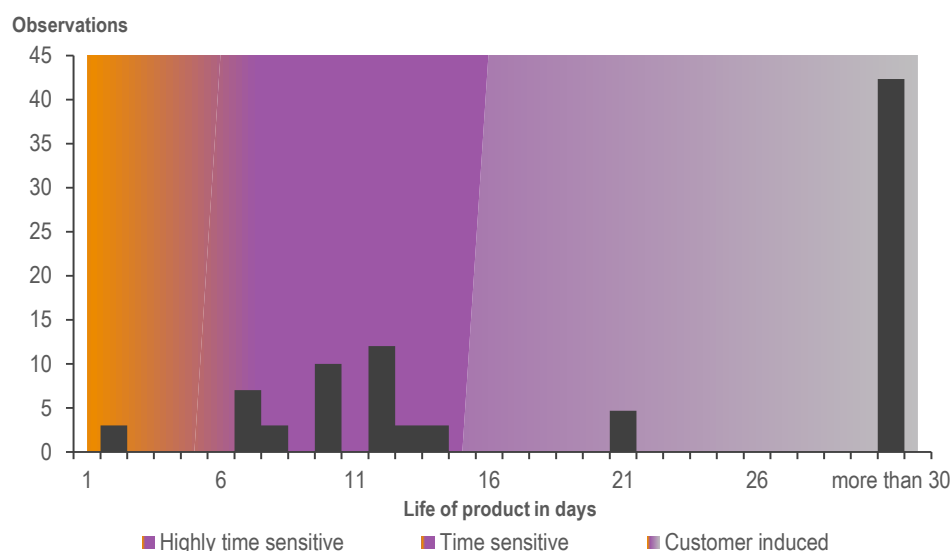
FIGURE 2.1 MARKET SEGMENTS BY LIFE OF PRODUCT

SOURCE: TASMANIAN INDUSTRY (INTERVIEWS WITH ACIL ALLEN, 2016)

The figure shows three distinct groups of observations: The first shows a product life of two days, the second between seven and 14 days and the last at 21 or more days. There were no observations between these groups. Consequently these three groups were used as the three market segments underpinning the analysis in this report.

Table 2.2 presents each of the time sensitive freight products produced in Tasmania by market segment. The three market segments are then described below.

TABLE 2.2 TASMANIAN TIME SENSITIVE FREIGHT PRODUCTS BY MARKET SEGMENT

Highly time sensitive freight	Time sensitive freight	Customer induced time sensitivity
Abalone	Blackberries	Apples
Lobster	Blueberries	Beans
	Cherries	Broccoli
	Cut flowers	Carrots
	Milk	Fresh meat
	Mussels	Frozen meat
	Oysters	Milk products (cheese)
	Raspberries	Onions
	Salads	Other brassica
	Salmon	Other vegetables
	Stonefruit other than cherries	Pears
	Strawberries	Poppies
	Tomatoes	Potatoes

SOURCE: ACIL ALLEN ANALYSIS OF TASMANIAN INDUSTRY DATA (INTERVIEWS WITH ACIL ALLEN, 2016)

2.4.1 Highly time sensitive products

Highly time sensitive products are those that have a very short shelf life and will perish within a few days. They therefore require a very fast route to market in order to preserve their product integrity and

to maintain their price expectation. Production of these types of product is often very seasonal and is driven by demand or harvesting windows. The willingness to pay for these products tends to be high.

Only abalone and lobsters are considered highly time sensitive under the above definition. The key processing centre for these products is located in Hobart and the majority of exports are flown out of Hobart Airport.

The risk assessment undertaken for the highly time sensitive segment showed that both products have an average risk. Their relative disadvantage in terms of volume and time sensitivity is compensated by the proximity of processing centres to the main export point at Hobart Airport, a relatively even seasonality and high market price, which supports the use of air freight.

2.4.2 Time sensitive products

Time sensitive products are those that will perish within approximately two weeks and consequently require fast routes to market. Production is often seasonal because of harvesting windows.

There are two processing centre clusters- one around Devonport and the other around Hobart. This aligns with production, which mainly occurs in the north west and south east. The majority of time sensitive products are exported by sea. This segment is also the largest agriculture related customer of Hobart Airport of each of the three market segments.

In terms of risk, with the exception of cherries and other berries, seasonality is generally not a major issue in this market segment. Volumes tend to be relatively low. The two processing clusters identified above result in high location risk for one group (those in the south) and very low risk for the other (those in the north). All products other than cherries, salmon, oysters and fresh milk are, according to the modelling, in the lowest two price categories indicating that the air freight potential of most products is relatively low.

With the highest average risk of the three market segments, time sensitive freight is likely to be most exposed to potential inefficiencies or capacity constraints along the supply chains. This high average risk is largely triggered by the combination of average to low value and average to low volume found in this group.

As noted above, in relation to milk, this segment only includes fresh milk volumes (the key export commodity); it excludes on-island volumes diverted to processed products. Demand for fresh milk exports is currently around 10,000 tonnes per annum.

2.4.3 Products with customer induced time sensitivity

Products in this segment have a product life of 21 days or more, and can typically be stored for several months under the right conditions. For example, fresh meat, if vacuum packed, can be stored for up to 90 days. Since they tend to be delivered to customers on a just in time basis, they require reliable routes to market. Production can be seasonal because of harvesting windows.

The key processing centres for this segment are located in the North and North West. Production is highest in the North West, however the North and South also generate significant volumes of product in this market segment. Products with customer induced time sensitivity depart Tasmania by ship across Bass Strait. About two thirds are containerised and (most likely) exported via the Port of Burnie, and one third leave Tasmania in trailers (most likely) from the Port of Devonport.

In terms of risk, seasonality is generally not a major issue in this market segment. Volumes tend to be relatively high. Apples and pears are the only products with major processing centres in the south and are consequently the only two products with major locational disadvantages. Apart from fresh meat, all products are in the lowest two price categories, indicating that the air freight potential for most products is low.

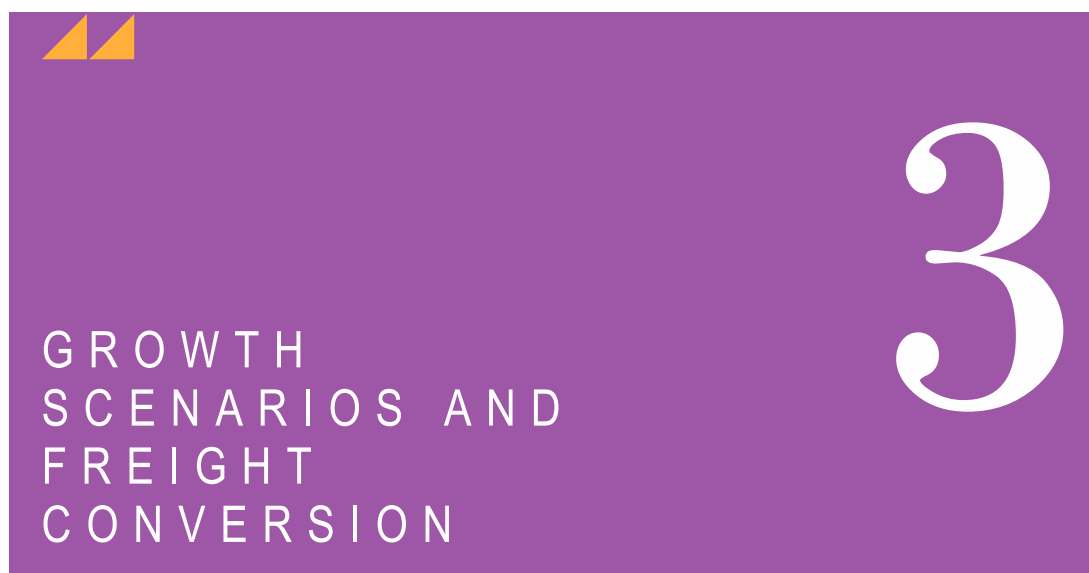

This chapter translates the base production estimates into freight demand projections, under three key growth scenarios.

3.1 Scenario development

Deriving reliable growth forecasts for Tasmania's time sensitive freight market is challenging. The future production of many commodities is subject to significant and unknown variability (e.g. climatic factors affecting yield and seasonality, market demand and commodity prices). This is compounded by the varying reliability of data across commodities.

ACIL-Allen developed three freight demand scenarios, using two very different approaches. The first approach is based on the producers' growth aspirations stated during consultation (Tasmanian industry, 2016) while the second approach is based on three to five year trends in the yield and area planted by commodity and region (SA4) recorded in ABS catalogue 7121: Agricultural Commodities (Australian Bureau of Statistics, 2014-15).

The scenarios consider a five-year forecast period from July 2016 to July 2021, beyond which the reliability of any market forecast reduces significantly.

The scenarios are:

1. **Producer aspiration scenario**
Under this scenario, five-year growth targets of major producers are converted into producer-specific annual compound growth rates that are applied to the associated base (current) production level over the next five years. For unspecified producers not interviewed by ACIL Allen, the high growth rate for agriculture, developed as part of the Burnie to Hobart Freight Corridor Strategy is applied (growth rate of 2.4 per cent, with annual growth of 0.4 per cent - refer to Burnie to Hobart Freight Corridor Strategy: Freight demand analysis (ACIL Allen Consulting, 2016)). For most commodities, this scenario forecasts higher growth than the other two scenarios.
2. **ABS based high growth scenario**
This scenario presents an optimistic extrapolation of recent ABS data. The ABS data shows significant recent contractions for a number of commodities and regions. In this scenario, the projected growth rates of these commodities are set to zero. For commodities showing positive recent growth, the higher growth rate of either area or the area multiplied by yield is used for the projection. If no data is available, the medium growth rate for agriculture developed as part of the Burnie to Hobart Freight Corridor Strategy is used (growth rate of 2.4 per cent, with no annual growth)
3. **ABS based low growth scenario**
This scenario presents a more negative extrapolation of recent ABS data. It uses the more negative growth rate of either area or the area multiplied by yield if the ABS data indicates a recent contraction.

If the ABS data indicates recent growth, the lower growth rate of either area or the area multiplied by yield is used. If no data is available, a growth rate of zero is used.

Projected growth under the three scenarios is shown in Figure 3.1 and described in detail below. Both the producer aspiration scenario and the ABS-based high growth scenario exhibit a strong upwards trend. Under the ABS-based low growth scenario, however, production decreases by about 10 per cent over the next five years. Growth rates differ substantially across market segments.

FIGURE 3.1 RELATIVE GROWTH BY SCENARIO, 2016 TO 2021

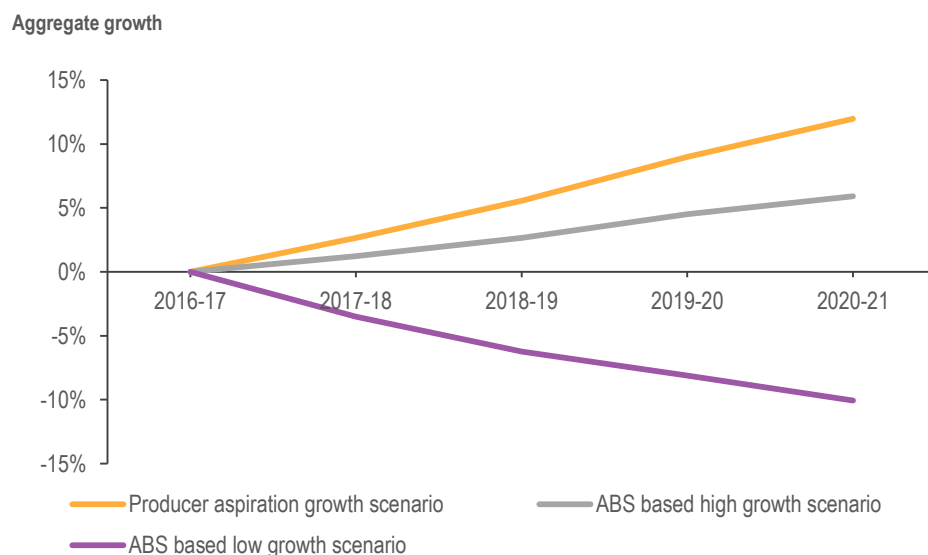

SOURCE: ACIL ALLEN ANALYSIS OF TASMANIAN INDUSTRY DATA (INTERVIEWS WITH ACIL ALLEN, 2016)

3.2 Producer aspiration scenario

Figure 3.2 summarises the producer aspiration scenario by presenting the aggregate relative growth by market segment over the study period. Under this scenario, growth is expected to be highest in the time sensitive freight segment.

FIGURE 3.2 PRODUCER ASPIRATION GROWTH SCENARIO - RELATIVE GROWTH BY SEGMENT, 2016 TO 2021

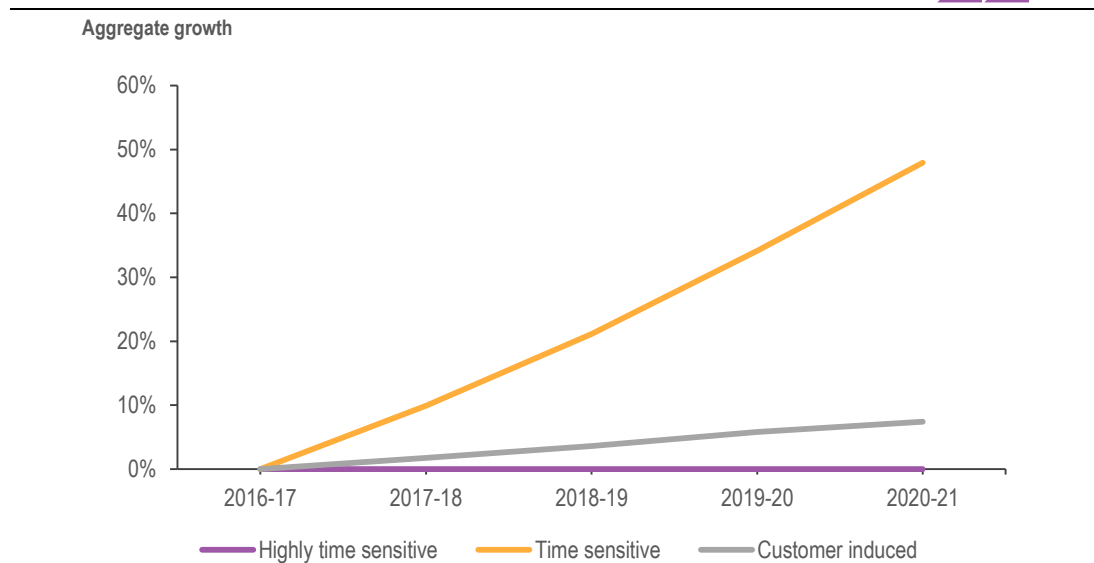

SOURCE: ACIL ALLEN ANALYSIS OF TASMANIAN INDUSTRY DATA (INTERVIEWS WITH ACIL ALLEN, 2016)

The following section examines growth in each of the three segments, by commodity, under this scenario.

3.2.1 Highly time sensitive market segment

Due to catch restrictions, no growth is expected in the highly time sensitive market segment. For the same reason there is no production in September and October. The production peak highlighted in Figure 3.3 reflects a higher market demand in those months.

FIGURE 3.3 PRODUCER ASPIRATION GROWTH – PRODUCTION HIGHLY TIME SENSITIVE MARKET SEGMENT

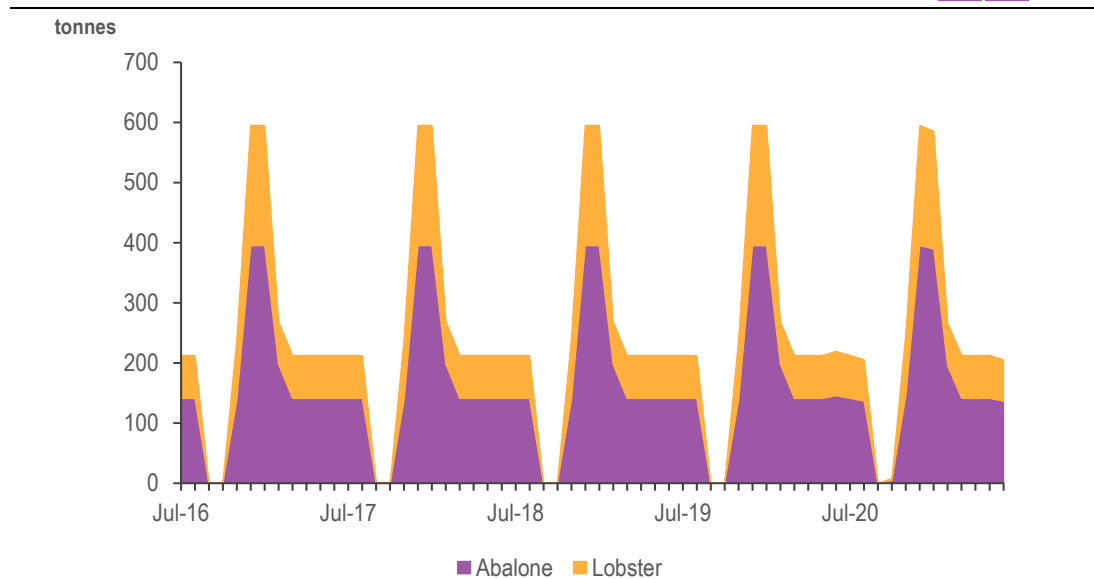

SOURCE: ACIL ALLEN ANALYSIS OF TASMANIAN INDUSTRY DATA (INTERVIEWS WITH ACIL ALLEN, 2016)

Table 3.1 below shows production tonnages and growth during the peak and trough months at the start and the end of the study period.

TABLE 3.1 PRODUCER ASPIRATION GROWTH – PRODUCTION HIGHLY TIME SENSITIVE FREIGHT

Product type	Trough 2016-17	Peak- 2016-17	Trough 2020-21	Peak 2020-21	Trough difference	Peak difference
Production, tonnes				Percentage change		
Abalone	0	395	0	395	0%	0%
Lobster	0	200	0	200	0%	0%
Total	0	595	0	595	0%	0%

SOURCE: ACIL ALLEN ANALYSIS OF TASMANIAN INDUSTRY DATA (INTERVIEWS WITH ACIL ALLEN, 2016)

3.2.2 Time sensitive market segment

ACIL Allen's analysis indicates that the time sensitive market segment is associated with the strongest growth expectations. If all producers meet their expectations, production in this segment would increase at an average annual (compound) rate of 8.2 per cent or by a total of 50 per cent over the next five years.

The time sensitive market segment contains 13 product types. Their specific production growth is presented in Figure 3.4. Production projections are shown separately for salmon and fresh milk, both relatively high volume products that are also subject to very limited seasonality, and the remainder of the market segment.

The fresh milk for export shown here represents target export volumes. After a short ramp up phase over the next few months, this task is expected to remain stable over the study period at around 830 tonnes per month. Salmon producers indicated strong growth ambitions which, if met, would see an increase from current production of about 4,500 tonnes per month to over 7,200 tonnes in 2020-21.

Under the producer aspiration scenario, peak period production for the remaining time sensitive products is projected to grow from about 4,000 tonnes to over 6,000 tonnes over the next five years. The very distinct seasonality is driven by cherries and berries.

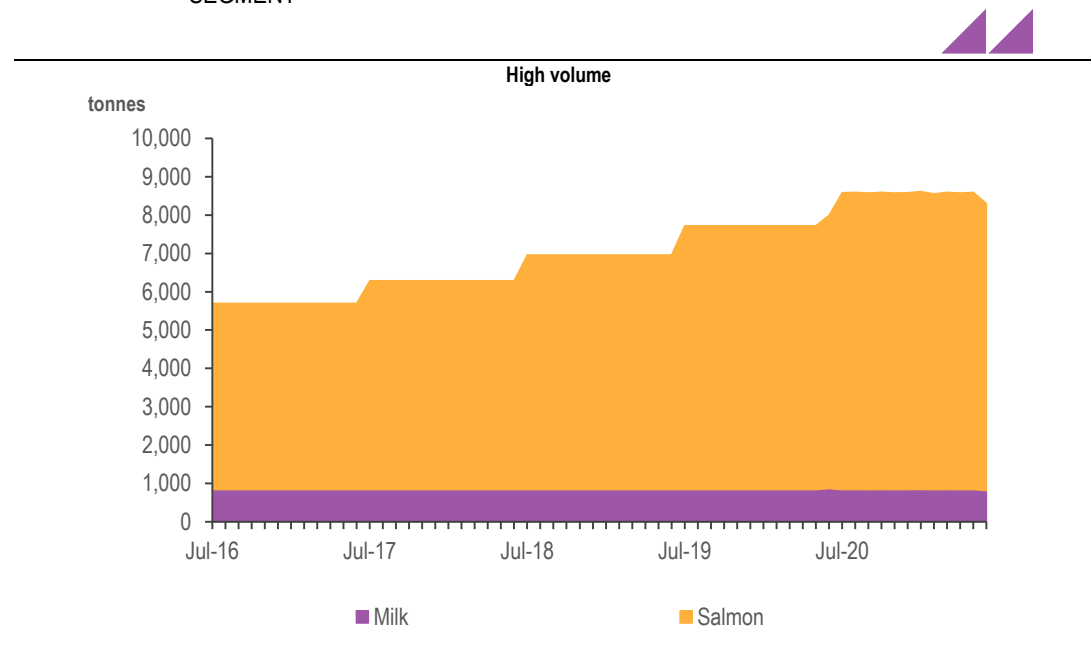
FIGURE 3.4 PRODUCER ASPIRATION GROWTH – PRODUCTION TIME SENSITIVE MARKET SEGMENT

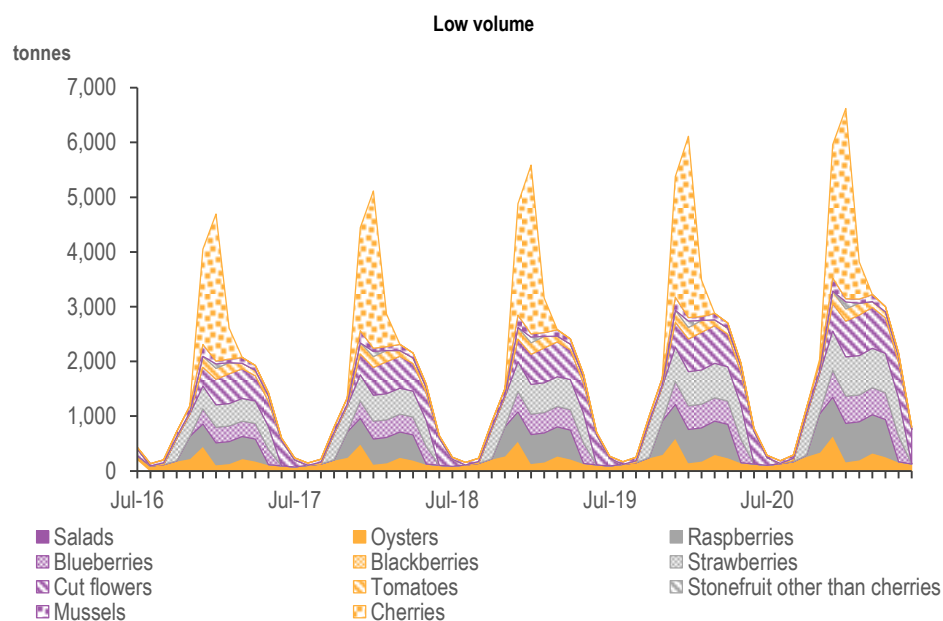

SOURCE: ACIL ALLEN ANALYSIS OF TASMANIAN INDUSTRY DATA (INTERVIEWS WITH ACIL ALLEN, 2016)

Table 3.2 shows production tonnages and growth during peak and trough months at the start and the end of the study period.

TABLE 3.2 PRODUCER ASPIRATION GROWTH – PRODUCTION TIME SENSITIVE MARKET SEGMENT

Product type	Trough 2016-17	Peak- 2016-17	Trough 2020-21	Peak 2020-21	Trough difference	Peak difference
Blackberries	0	100	0	175	0%	75%
Blueberries	0	283	0	495	0%	75%
Cherries	0	2,690	0	3,475	0%	29%
Cut flowers	20	80	22	92	11%	15%
Milk	833	833	806	836	-3%	0%
Mussels	32	216	38	242	16%	12%
Oysters	68	455	101	649	48%	43%
Raspberries	0	400	0	699	0%	75%
Salads	210	971	241	1,135	15%	17%
Salmon	4,867	5,458	7,497	7,782	54%	43%
Stone fruit other than cherries	0	80	0	128	0%	60%
Strawberries	0	413	0	721	0%	75%
Tomatoes	0	200	0	219	0%	10%
Total	6,031	12,179	8,704	16,649	47%	39%

Note: Table subject to rounding errors

SOURCE: ACIL ALLEN ANALYSIS OF TASMANIAN INDUSTRY DATA (INTERVIEWS WITH ACIL ALLEN, 2016)

3.2.3 Customer induced market segment

Under this scenario the customer induced market segment is expected to experience moderate growth. If all producers meet their expectations, production in this segment would increase at an average annual (compound) rate of 1.5 per cent or by a total of eight per cent over the next five years.

The customer induced time sensitivity market segment contains 13 product types. Production growth is presented in Figure 3.5. The figure contains two diagrams which separate total production into relatively high and relatively low volume products.

FIGURE 3.5 PRODUCER ASPIRATION GROWTH – PRODUCTION CUSTOMER INDUCED TIME SENSITIVITY MARKET SEGMENT

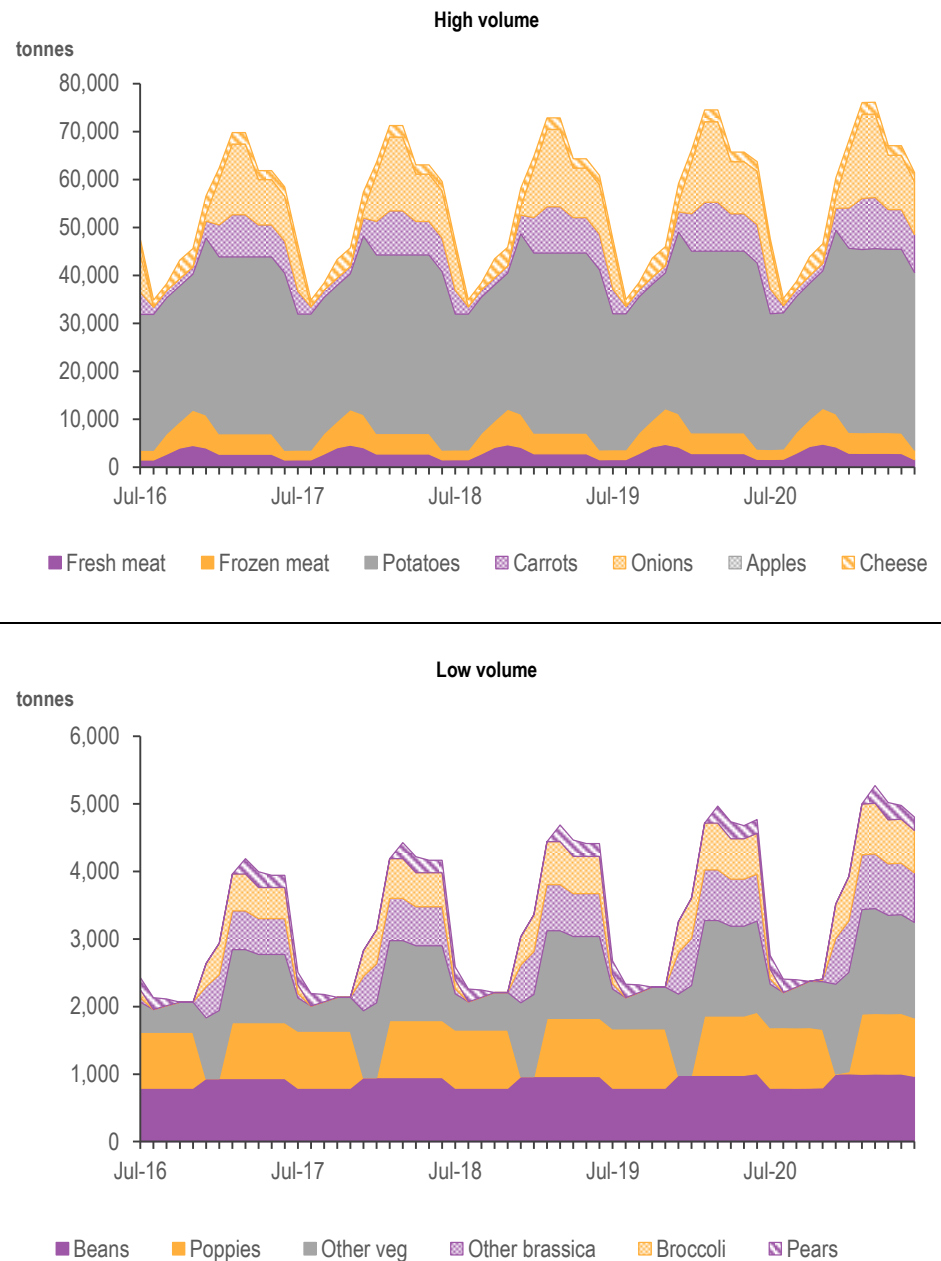

SOURCE: ACIL ALLEN ANALYSIS OF TASMANIAN INDUSTRY DATA (INTERVIEWS WITH ACIL ALLEN, 2016)

The high volume group is dominated by potatoes, carrots and onions. Carrots and potatoes are sold as fresh and frozen products and exhibit limited export seasonality as trade does not depend on harvesting windows. Onions can be stored for long periods without being frozen.

With a peak production of 10,000 tonnes, meat products (fresh and frozen) are the second major product type in this group.

The low volume group contains beans which show very limited seasonality (and no growth) as they are mainly frozen before leaving Tasmania. All other products in this category are associated with a distinct harvest induced production peak in late summer and early autumn.

Under the producer aspiration scenario, production in the peak month for this product group is projected to grow from about 4,000 tonnes to over 5,000 tonnes over the next five years.

Table 3.3 shows production tonnages and growth during the peak and trough months at the start and the end of the study period.

TABLE 3.3 PRODUCER ASPIRATION GROWTH – PRODUCTION CUSTOMER INDUCED TIME SENSITIVITY MARKET SEGMENT

Product type	Trough 2016-17	Peak- 2016-17	Trough 2020-21	Peak 2020-21	Trough difference	Peak difference
	Production, tonnes			Percentage change		
Apples	0	3,975	0	4,644	0%	17%
Beans	792	935	791	1,004	0%	7%
Broccoli	0	543	0	746	0%	37%
Carrots	1,542	8,742	1,540	10,710	0%	23%
Cheese	1,430	3,813	1,490	3,976	4%	4%
Fresh meat	1,518	4,547	1,581	4,831	4%	6%
Frozen meat	2,032	7,378	2,007	7,468	-1%	1%
Onions	0	14,766	0	17,508	0%	19%
Other brassica	0	574	0	815	0%	42%
Other vegetables	336	1,083	517	1,549	54%	43%
Pears	0	216	0	245	0%	14%
Poppy straw	0	844	0	897	0%	6%
Potatoes	28,333	36,905	28,303	38,415	0%	4%
Total	35,983	84,524	36,229	93,023	1%	11%

Note: Table subject to rounding errors

SOURCE: ACIL ALLEN ANALYSIS OF TASMANIAN INDUSTRY DATA (INTERVIEWS WITH ACIL ALLEN, 2016)

3.3 ABS based high growth scenario

Figure 3.6 summarises the scenario by presenting the aggregate relative growth by market segment over the study period. Compared with the producer aspiration scenario, this scenario predicts similar growth in the time sensitive market segment but lower growth in the customer induced time sensitive freight segment.

The remainder of this section presents the associated production tonnages for each of the three segments, by product type.

FIGURE 3.6 ABS BASED HIGH GROWTH SCENARIO - RELATIVE GROWTH BY SEGMENT, 2016 TO 2021

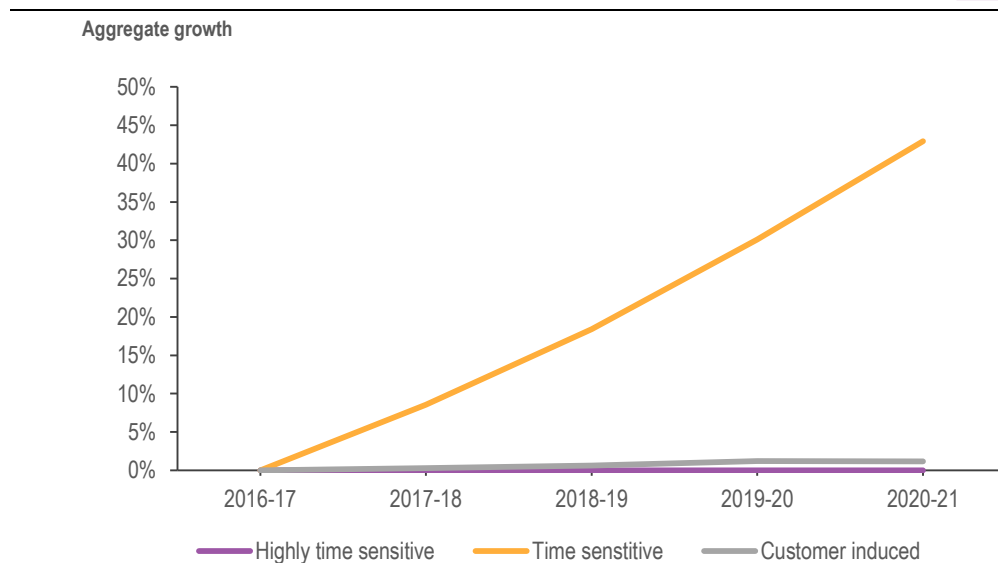

SOURCE: SOURCE: ACIL ALLEN ANALYSIS OF ABS CATALOGUE 7121

3.3.1 Highly time sensitive market segment

Due to catch restrictions, no growth is expected in the highly time sensitive market segment. For the same reason there is no production in September and October. The production peak highlighted in Figure 3.7 is a result of higher market demand during these months.

FIGURE 3.7 ABS BASED HIGH GROWTH SCENARIO – PRODUCTION HIGHLY TIME SENSITIVE FREIGHT

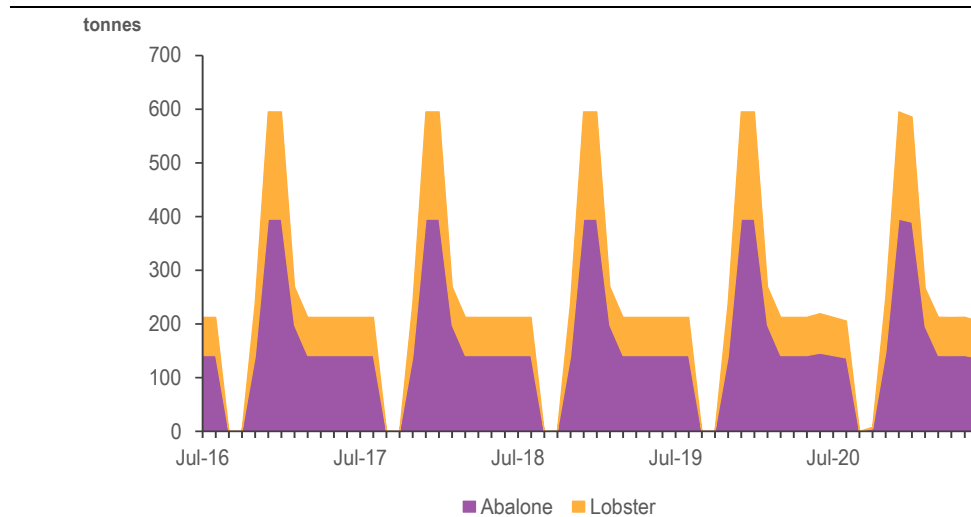

SOURCE: ACIL ALLEN ANALYSIS OF TASMANIAN INDUSTRY DATA (INTERVIEWS WITH ACIL ALLEN, 2016)

Table 3.4 shows the production tonnages and growth during the peak and trough months at the start and the end of the study period.

TABLE 3.4 ABS BASED HIGH GROWTH SCENARIO – PRODUCTION HIGHLY TIME SENSITIVE FREIGHT

Product type	Trough 2016-17	Peak- 2016-17	Trough 2020-21	Peak 2020-21	Trough difference	Peak difference
	Production, tonnes			Percentage change		
Abalone	0	395	0	395	0%	0%
Lobster	0	200	0	200	0%	0%
Total	0	595	0	595	0%	0%

SOURCE: ACIL ALLEN ANALYSIS OF TASMANIAN INDUSTRY (INTERVIEWS WITH ACIL ALLEN, 2016) AND ABS CATALOGUE 7121 DATA

3.3.2 Time sensitive freight market

The time sensitive market segment is projected to grow faster than other segments at an average annual (compound) rate of 7.5 per cent or by a total 43 per cent over the next five years. The time sensitive market segment contains 13 product types. Their specific production growth is presented in Figure 3.8.

The fresh milk for export shown here represents the target volume. After a short ramp up phase over the next few months, it is expected to remain stable over the study period at about 830 tonnes per month. As these volumes consider the VDL milk task only, volumes are the same as under the Producer Aspiration scenario (Figure 3.4). Forecast growth in salmon results in an increase from current production of about 4,500 tonnes per month to over 6,500 tonnes in 2020-21.

Peak period production for the remaining time sensitive products is projected to grow from about 4,000 tonnes to over 6,000 tonnes over the next five years. The very distinct seasonality is driven by cherries and berries.

FIGURE 3.8 ABS BASED HIGH GROWTH SCENARIO – PRODUCTION TIME SENSITIVE FREIGHT



SOURCE: ACIL ALLEN ANALYSIS OF TASMANIAN INDUSTRY (INTERVIEWS WITH ACIL ALLEN, 2016) AND ABS CATALOGUE 7121 DATA

Table 3.5 below shows the production tonnages and growth during the peak and trough months at the start and the end of the study period.

TABLE 3.5 ABS BASED HIGH GROWTH SCENARIO – PRODUCTION TIME SENSITIVE MARKET SEGMENT

Product type	Trough 2016-17	Peak- 2016-17	Trough 2020-21	Peak 2020-21	Trough difference	Peak difference
	Production, tonnes				Percentage change	
Blackberries	0	100	0	292	0%	192%
Blueberries	0	283	0	828	0%	192%
Cherries	0	2,690	0	2,623	0%	-2%
Cut flowers	20	80	20	83	1%	4%
Milk	833	833	806	836	-3%	0%
Mussels	32	216	33	211	1%	-2%
Oysters	68	455	84	539	23%	19%
Raspberries	0	400	0	1,169	0%	192%
Salads	210	971	289	1,308	38%	35%
Salmon	4,867	5,276	6,497	6,744	33%	28%
Stonefruit other than cherries	0	80	0	77	0%	-3%
Strawberries	0	413	0	1,205	0%	192%
Tomatoes	0	200	0	201	0%	0%
Total	6,031	11,997	7,728	16,118	29%	56%

TABLE SUBJECT TO ROUNDING ERRORS

SOURCE: ACIL ALLEN ANALYSIS OF TASMANIAN INDUSTRY (INTERVIEWS WITH ACIL ALLEN, 2016) AND ABS CATALOGUE 7121 DATA

3.3.3 Customer-induced market segment

Under this scenario the customer induced time sensitivity market segment is expected to experience very limited growth over the next five years. Based on an optimistic interpretation of the ABS data, production in this segment would increase at an average annual (compound) rate of 0.3 per cent or by a total of one per cent over the next five years.

The customer induced time sensitivity market segment contains 13 product types. Their specific production growth is presented in Figure 3.9.

FIGURE 3.9 ABS BASED HIGH GROWTH SCENARIO – PRODUCTION FREIGHT WITH CUSTOMER INDUCED TIME SENSITIVITY

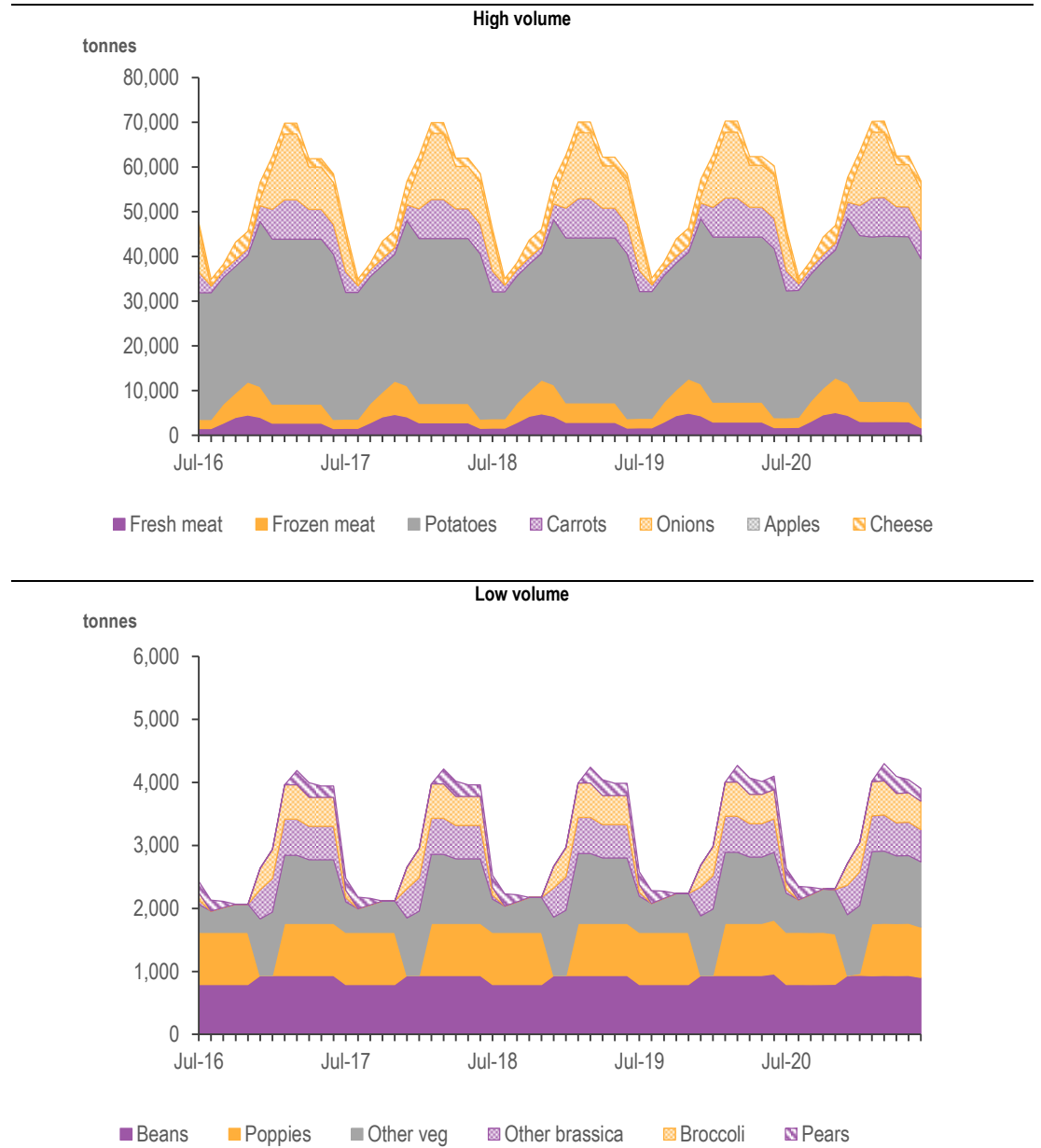

SOURCE: ACIL ALLEN ANALYSIS OF TASMANIAN INDUSTRY (INTERVIEWS WITH ACIL ALLEN, 2016) AND ABS CATALOGUE 7121 DATA

Table 3.6 shows the production tonnages and growth during the peak and trough months at the start and the end of the study period.

TABLE 3.6 ABS BASED HIGH GROWTH SCENARIO – PRODUCTION CUSTOMER INDUCED TIME SENSITIVITY MARKET SEGMENT

Product type	Trough 2016-17	Peak- 2016-17	Trough 2020-21	Peak 2020-21	Trough difference	Peak difference
	Production, tonnes			Percentage change		
Apples	0	3,975	0	3,979	0%	0%
Beans	792	935	791	938	0%	0%
Broccoli	0	543	0	541	0%	0%
Carrots	1,542	8,742	1,540	8,711	0%	0%
Cheese	1,430	3,813	1,458	3,892	2%	2%
Fresh meat	1,518	4,547	1,681	5,097	11%	12%
Frozen meat	2,032	7,378	2,115	7,757	4%	5%
Onions	0	14,766	0	14,715	0%	0%
Other brassica	0	574	0	573	0%	0%
Other vegetables	336	1,083	517	1,145	54%	6%
Pears	0	216	0	256	0%	19%
Poppy straw	0	828	0	828	0%	0%
Potatoes	28,333	36,905	28,303	37,032	0%	0%
Total	35,983	84,303	36,405	85,465	1%	2%

TABLE SUBJECT TO ROUNDING ERRORS

SOURCE: ACIL ALLEN ANALYSIS OF TASMANIAN INDUSTRY (INTERVIEWS WITH ACIL ALLEN, 2016) AND ABS CATALOGUE 7121 DATA

3.4 ABS based low growth scenario

The ABS based low growth scenario represents a relatively negative extrapolation of the historical data. Figure 3.10 summarises the scenario by presenting the aggregate relative growth by market segment over the study period. The figure shows that even under very conservative assumptions, the time sensitive market segment grows by about 10 per cent over the next five years. The market segment with customer induced time sensitivity, however, contracts by just under 15 per cent under this scenario.

The remainder of this section presents the associated production tonnages for each product type.

FIGURE 3.10 ABS BASED LOW GROWTH SCENARIO - RELATIVE GROWTH BY SEGMENT, 2016 TO 2021

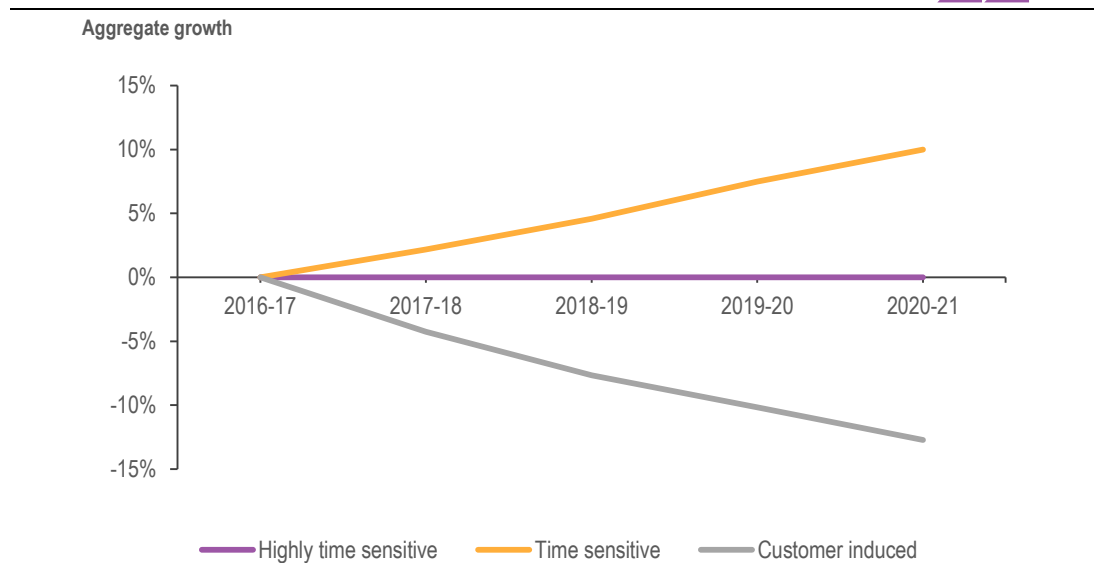

SOURCE: SOURCE: ACIL ALLEN ANALYSIS OF ABS CATALOGUE 7121

3.4.1 Highly time sensitive market segment

Due to catch restrictions, no growth is expected in the highly time sensitive market segment. For the same reason there is no production in September and October. The production peak highlighted in Figure 3.11 reflects higher market demand during these months.

FIGURE 3.11 ABS BASED LOW GROWTH SCENARIO – PRODUCTION HIGHLY TIME SENSITIVE FREIGHT

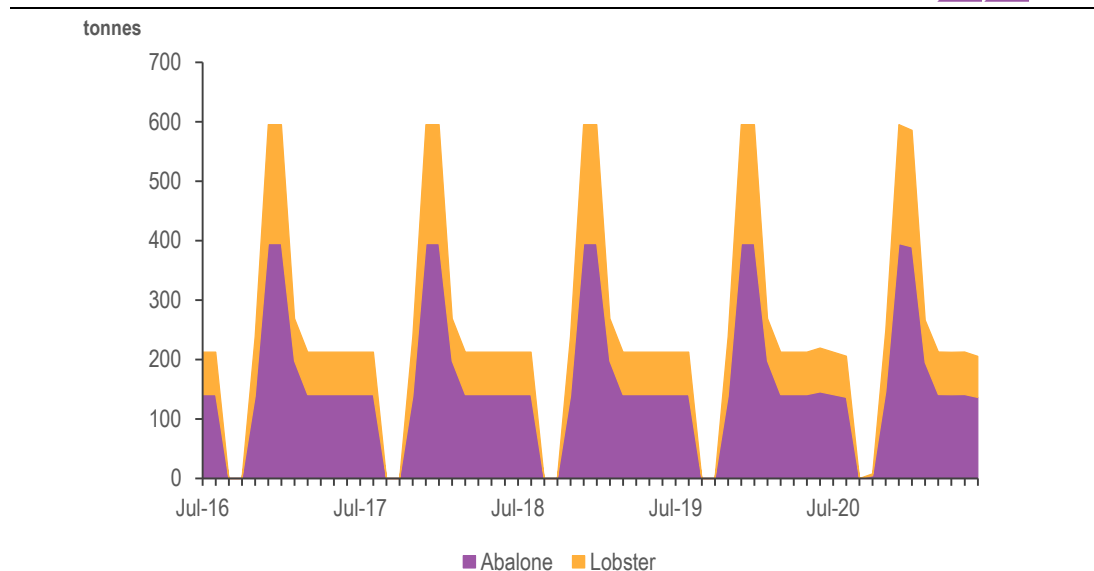

SOURCE: ACIL ALLEN ANALYSIS OF TASMANIAN INDUSTRY (INTERVIEWS WITH ACIL ALLEN, 2016) AND ABS CATALOGUE 7121 DATA

Table 3.7 shows the production tonnages and growth during peak and trough months at the start and the end of the study period.

TABLE 3.7 ABS BASED LOW GROWTH SCENARIO – PRODUCTION HIGHLY TIME SENSITIVE FREIGHT

Product type	Trough 2016-17	Peak- 2016-17	Trough 2020-21	Peak 2020-21	Trough difference	Peak difference
Production, tonnes				Percentage change		
Abalone	0	395	0	395	0%	0%
Lobster	0	200	0	200	0%	0%
Total	0	595	0	595	0%	0%

SOURCE: ACIL ALLEN ANALYSIS OF TASMANIAN INDUSTRY (INTERVIEWS WITH ACIL ALLEN, 2016) AND ABS CATALOGUE 7121 DATA

3.4.2 Time sensitive market segment

The time sensitive market segment is associated with the strongest growth expectations under this scenario. Production in this segment is expected to increase at an average annual (compound) rate of two per cent or by a total 10 per cent over the next five years. The time sensitive market segment contains 13 product types. Their specific production growth is presented in Figure 3.12.

As above, the fresh milk export volumes represent the target volume, and after a short ramp-up phase, are expected to remain stable over the study period at about 830 tonnes per month. Salmon production is forecast to increase from 4,500 tonnes per month to just over 5,150 tonnes in 2020-21.

Peak period production for the remaining time sensitive products is projected to grow only slightly, averaging around 4,000 tonnes per annum. The very distinct seasonality is driven by cherries and berries. Under this scenario, growth in the production of berries offsets a forecast contraction in cherry production.

FIGURE 3.12 ABS BASED LOW GROWTH SCENARIO – PRODUCTION TIME SENSITIVE FREIGHT

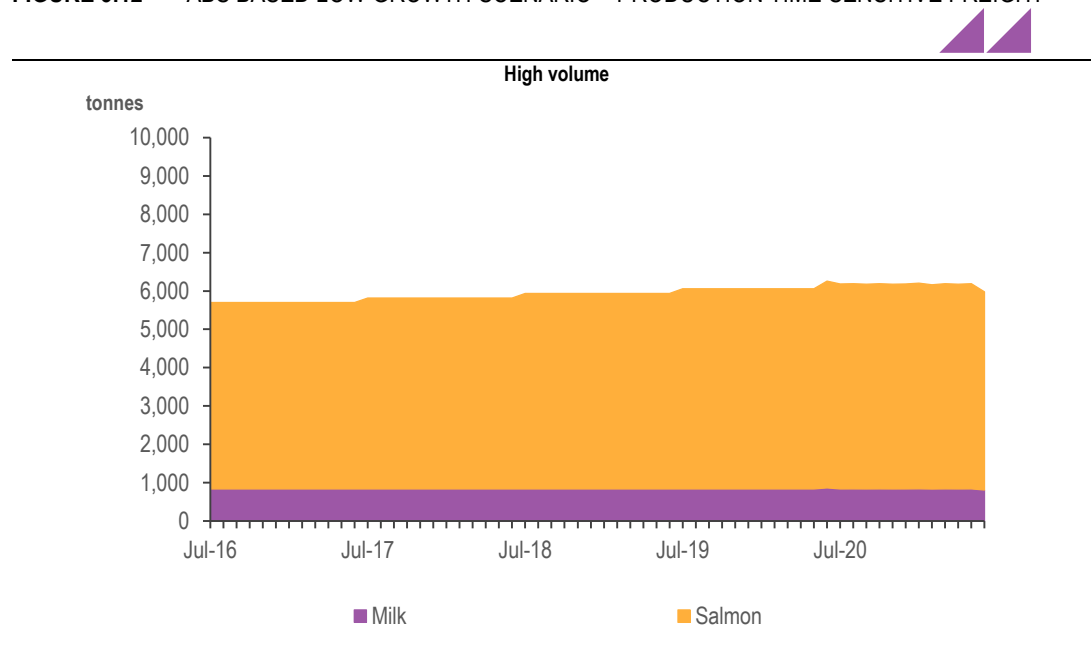

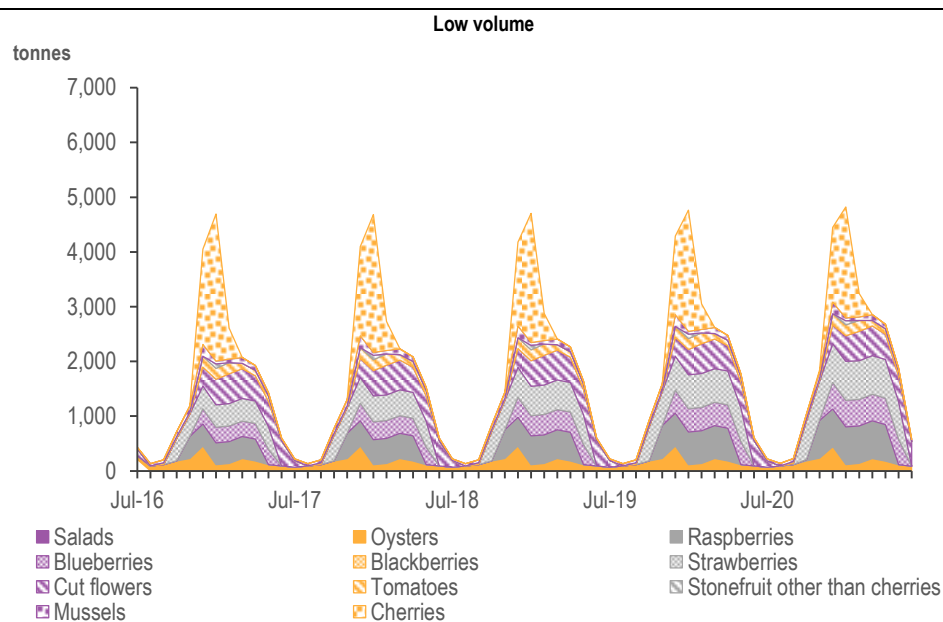

SOURCE: ACIL ALLEN ANALYSIS OF TASMANIAN INDUSTRY (INTERVIEWS WITH ACIL ALLEN, 2016) AND ABS CATALOGUE 7121 DATA

Table 3.8 shows production tonnages and growth during the peak and trough months at the start and the end of the study period.

TABLE 3.8 ABS BASED LOW GROWTH SCENARIO – PRODUCTION TIME SENSITIVE MARKET SEGMENT

Product type	Trough 2016-17	Peak- 2016-17	Trough 2020-21	Peak 2020-21	Trough difference	Peak difference
Blackberries	0	100	0	172	0%	72%
Blueberries	0	283	0	487	0%	72%
Cherries	0	2,690	0	2,024	0%	-25%
Cut flowers	20	80	15	64	-23%	-20%
Milk	833	833	806	836	-3%	0%
Mussels	32	216	33	211	1%	-2%
Oysters	68	455	69	444	1%	-2%
Raspberries	0	400	0	688	0%	72%
Salads	210	971	187	869	-11%	-11%
Salmon	4,867	4,983	5,173	5,369	6%	8%
Stonefruit other than cherries	0	80	0	76	0%	-5%
Strawberries	0	413	0	710	0%	72%
Tomatoes	0	200	0	201	0%	0%
Total	6,031	11,704	6,282	12,151	4%	11%

TABLE SUBJECT TO ROUNDING ERRORS

SOURCE: ACIL ALLEN ANALYSIS OF TASMANIAN INDUSTRY (INTERVIEWS WITH ACIL ALLEN, 2016) AND ABS CATALOGUE 7121 DATA

3.4.3 Customer induced market segment

Under this scenario, the customer induced time sensitivity market segment is expected to contract over the next five years, at an average annual (compound) rate of 2.7 per cent or by a total of 13 per cent.

The customer induced time sensitivity market segment contains 13 product types. Their specific production growth is presented in Figure 3.13. The high volume group (fresh potatoes, fresh carrots and onions) is the main group forecast to contract over the next five years, decreasing from about 60,000 tonnes to below 50,000 tonnes by 2021.

FIGURE 3.13 ABS BASED LOW GROWTH SCENARIO – PRODUCTION FREIGHT WITH CUSTOMER INDUCED TIME SENSITIVITY

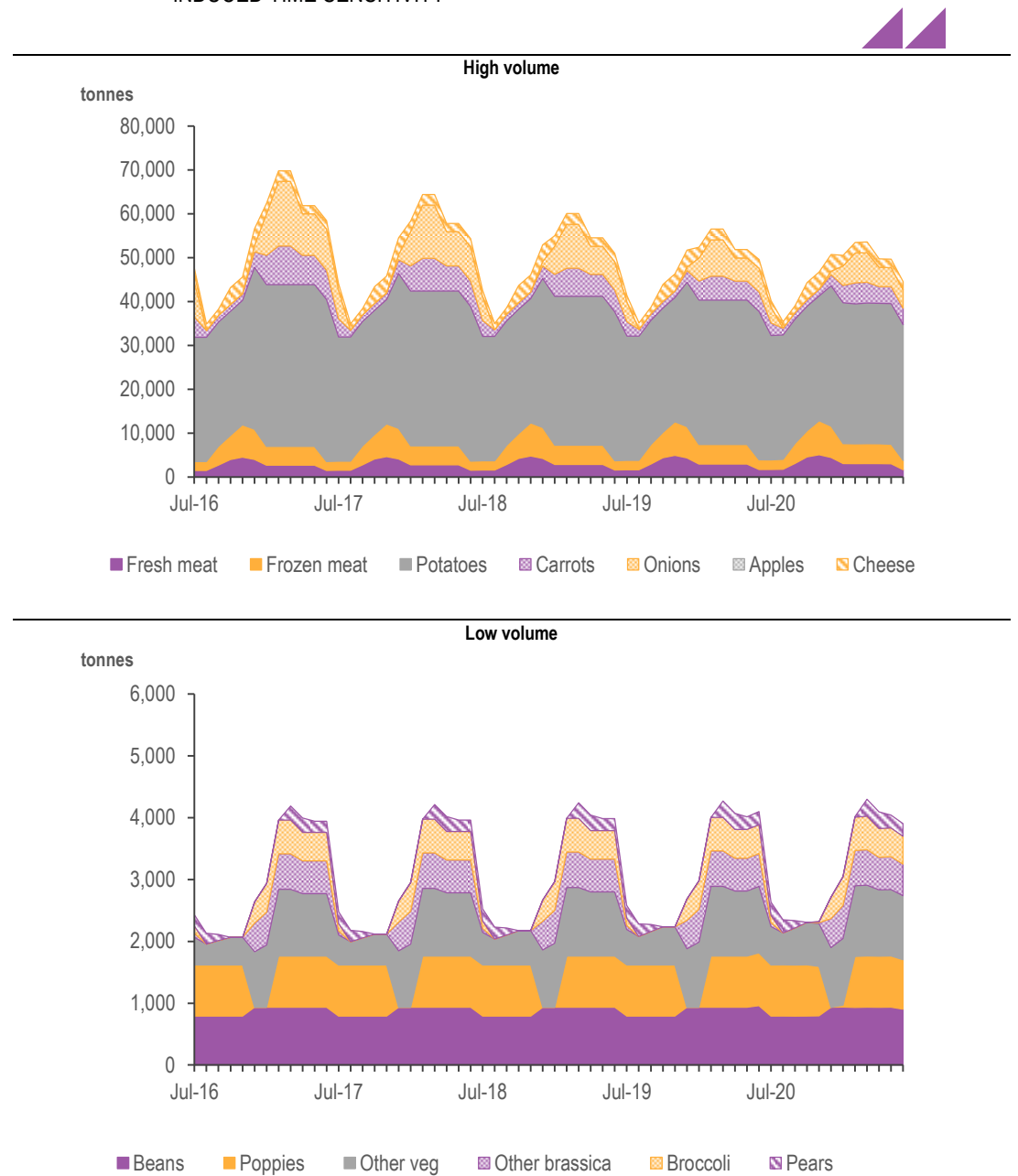

TABLE SUBJECT TO ROUNDING ERRORS
 SOURCE: ACIL ALLEN ANALYSIS OF TASMANIAN INDUSTRY (INTERVIEWS WITH ACIL ALLEN, 2016) AND ABS CATALOGUE 7121 DATA

With a peak production of 10,000 tonnes, meat products (fresh and frozen) are the second key product type in this group. Production is forecast to increase from 85,000 tonnes per annum to 88,000 tonne per annum.

The low volume group contains beans which show very limited seasonality and no growth as they are mainly frozen before leaving Tasmania. All other products in this category are associated with a distinct harvest induced production peak in late summer and early autumn. Under the low growth scenario, peak period production for this product group is projected to grow from about 4,000 tonnes to over 5,000 tonnes over the next five years.

Table 3.9 shows the production tonnages and growth during the peak and trough months at the start and the end of the study period.

TABLE 3.9 ABS BASED LOW GROWTH SCENARIO – PRODUCTION CUSTOMER INDUCED TIME SENSITIVITY MARKET SEGMENT

Product type	Trough 2016-17	Peak- 2016-17	Trough 2020-21	Peak 2020-21	Trough difference	Peak difference
	Production, tonnes			Percentage change		
Apples	0	3,975	0	3,719	0%	-6%
Beans	792	935	791	938	0%	0%
Broccoli	0	543	0	541	0%	0%
Carrots	1,542	8,742	1,540	4,784	0%	-45%
Cheese	1,430	3,813	1,458	3,892	2%	2%
Fresh meat	1,518	4,547	1,681	5,097	11%	12%
Frozen meat	2,032	7,378	2,115	7,757	4%	5%
Onions	0	14,766	0	6,787	0%	-54%
Other brassica	0	574	0	573	0%	0%
Other vegetables	336	1,083	517	1,145	54%	6%
Pears	0	216	0	255	0%	19%
Poppy straw	0	828	0	828	0%	0%
Potatoes	28,333	36,905	28,303	32,134	0%	-13%
Total	35,983	84,303	36,405	68,450	1%	-13%

TABLE SUBJECT TO ROUNDING ERRORS

SOURCE: ACIL ALLEN ANALYSIS OF TASMANIAN INDUSTRY (INTERVIEWS WITH ACIL ALLEN, 2016) AND ABS CATALOGUE 7121 DATA

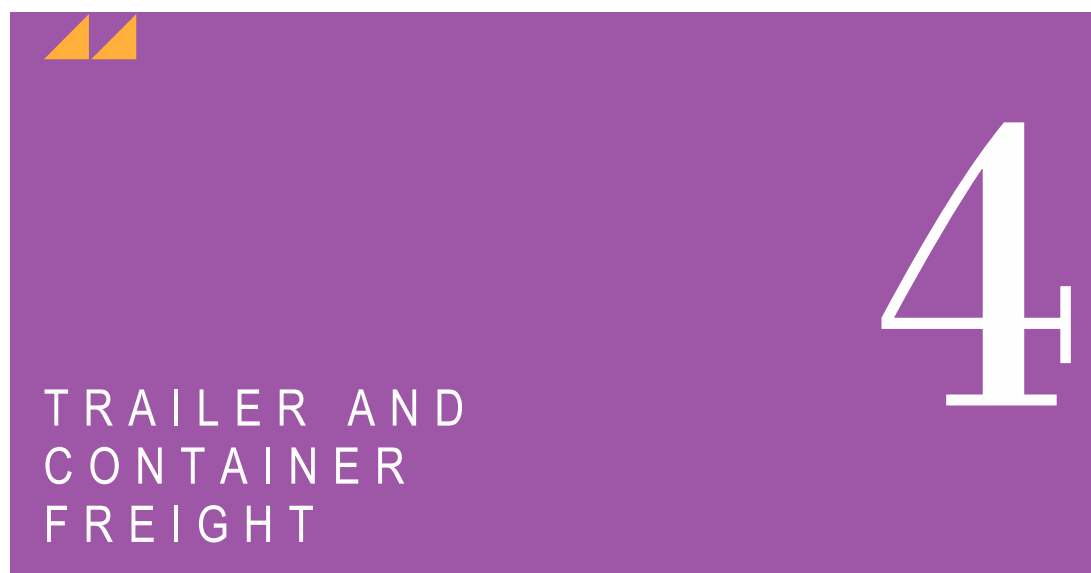

This chapter analyses trailer and container demand and capacity across Bass Strait, focusing on the time sensitive freight market.

In the context of the vessel replacement plans of operators, there is sufficient capacity in the market to meet forecast demand. However a continued preference to use TT-Line will create peak period capacity issues in the trailerised market. This chapter examines one potential scenario in relation to the level of shift in demand between operators that might be required to better manage peak period trailer volumes.

4.1 Freight movements across Bass Strait

Shipping plays a greater role in Tasmania's inter-state freight system compared with other Australian jurisdictions, with over 98 per cent of freight moved by sea. High-frequency domestic shipping services are provided by Toll-ANL, SeaRoad Shipping and TT-Line, operating between Devonport and Burnie ports and the Port of Melbourne. While service frequency is broadly consistent across the three operators, there are differences in service and schedule offerings sufficient to influence the decision-making of some businesses. For the time sensitive freight market, TT-Line is currently the preferred service provider for most producers and freight forwarders.

Tasmania's peak export season is February to June, with agriculture the main component of this market. For many time-sensitive freight commodities, export volumes are also highest from February to June, reflecting the seasonality of many commodities (such as cherries). During these peak periods, effective operating capacity across Bass Strait is close to 85 per cent. Over the next three years, both SeaRoad Shipping and Toll will introduce new and larger replacement vessels, which will significantly increase container and trailer capacity across Bass Strait. SeaRoad's first replacement vessel is now operational.

The majority of time sensitive freight is moved by sea to the Port of Melbourne, and then distributed throughout Australia or transferred to Melbourne Airport for transport to international markets. Small amounts of (highly time sensitive) products are exported direct from Hobart Airport to interstate and international destinations. As there is no direct international air service from Tasmania yet, products exported internationally by air must transfer at Melbourne Airport before being forwarded to their final destinations, which are predominantly in China and South East Asia. From early 2017 onwards, a direct cargo-only flight will commence between Hobart and Ningbo in China.

Trailerised freight has developed as the key logistic preference for most time sensitive freight producers. Containers are preferred for higher bulk commodities, largely in the customer-induced segment (e.g. potatoes).

4.2 Trailer freight – overview of services

Trailers are used to either pick up product at a grower's packing shed (if volumes are sufficient) or from an aggregator/processor to deliver to a distribution centre or wholesale market either in Tasmania or Melbourne. Along this route, Tasmanian freight forwarders offer services that guarantee delivery from "paddock to wholesale market" within 24 hours.

In this study, a trailer is defined as an articulated vehicle consisting of a prime mover and (a typically refrigerated) 40 foot trailer.

TT-Line is the preferred service provider for the time sensitive freight market, offering a trailer-only service, a later freight delivery cut-off time, earlier arrival into Melbourne and shorter wharf clearance times.

In contrast, SeaRoad and Toll predominantly carry containers, and operate based on a mid-afternoon freight delivery cut-off time. Arrival into the Port of Melbourne is also slightly later compared with TT-Line. However SeaRoad and Toll will offer updated service schedules as part of their vessel replacement plans, which are expected to be more attractive to the time sensitive freight market. Both will also significantly increase their trailer capacity.

The key freight forwarders along the trailer freight supply chains are SRT Logistics and Fresh Freight. While SRT Logistics appears to have a focus on milk products and Fresh Freight on salmon, fruit and vegetables are a key part both companies' business. Consequently, they have relatively similar characteristics:

- both have freight hubs in Hobart, Launceston, Devonport and Melbourne
- both have grown substantially in the past decade
- both are specialised on the Tasmanian agriculture freight market and offer comprehensive packing shed to mainland wholesaler supply chain solutions.

Toll also offers trailer transport but it does not appear to be its core business.

Both SRT Logistics and Fresh Freight indicated trailers are their preferred mode of transport across Bass Strait, with trailers dropped on TT-Line and collected in Melbourne by a mainland based prime mover.

Based on the consultation and observations undertaken in this study, Tasmania appears to have a functional trailerised logistics sector, dominated by the two freight forwarders that provide specialised and effective services. Tasmania's land transport network is also efficient, with limited congestion or travel time reliability issues (ACIL Allen Consulting, 2016). It can therefore be expected that freight can be distributed within Tasmania without major issues for the foreseeable future.

4.3 Trailer freight – analysis of demand

Given the strong focus on trailerised freight within the time sensitive freight market, ACIL Allen considers the trailer trade from Tasmania to Melbourne a good indicator of broader market trends.

Based on the supply chain assumptions at least a share of the production of 22 of the 28 analysed product types crosses Bass Strait in a trailer. Figure 4.1 presents these 22 products, their market segment and the price risk score.

A price risk score of one or two makes a product a likely candidate for air freight, a score of three a possible candidate and scores of four and five, an unlikely one. This means that apart from cherries, fresh meat (score of 2) and potentially oysters and salmon (score of 3), all products rely on crossing Bass Strait via sea.

Figure 4.1 presents the projected (unconstrained) monthly demand for trailerised freight across Bass Strait by market segment and product type. The figure shows that demand is subject to a distinct seasonal pattern. Driven by salmon, time sensitive freight grows to over 800/1,600 TEU (trough/peak). Growth in the customer induced time sensitive freight segment is expected to be slower, with demand reaching 1,300 TEU at the end of the forecast period.

FIGURE 4.1 TRAILER FREIGHT – DEMAND PROJECTION, PRODUCER ASPIRATION SCENARIO

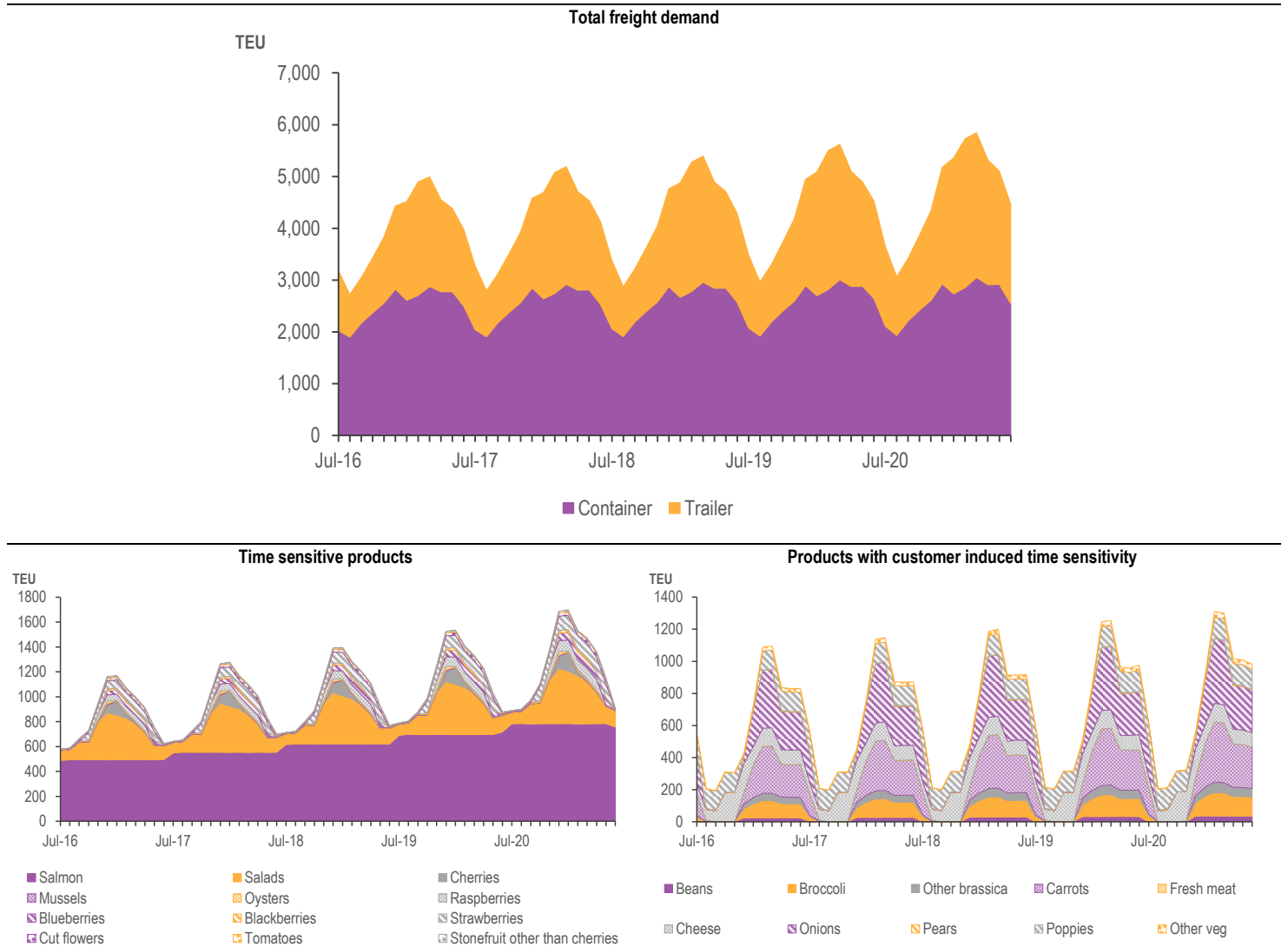

SOURCE: ACIL ALLEN ANALYSIS OF TASMANIAN INDUSTRY DATA (INTERVIEWS WITH ACIL ALLEN, 2016)

Figure 4.2 presents the monthly trailer volumes travelling from Tasmania to the Port of Melbourne by product category, using Port of Melbourne trade data. The figure shows that between 25 per cent (during the off-season) and just under 50 per cent (during peak season) of trailers transport agricultural products. On average, 35 per cent of trailerised freight is associated with agricultural products.

The figure indicates that potential capacity constraints could be triggered by an increase in the production of time sensitive products, livestock trailers or by an increasing (typically far less seasonal) base demand for trailerised transport (of non-time sensitive products) across Bass Strait. This indicates that, in assessing capacity across Bass Strait for this market, livestock and base demand should be taken into account.

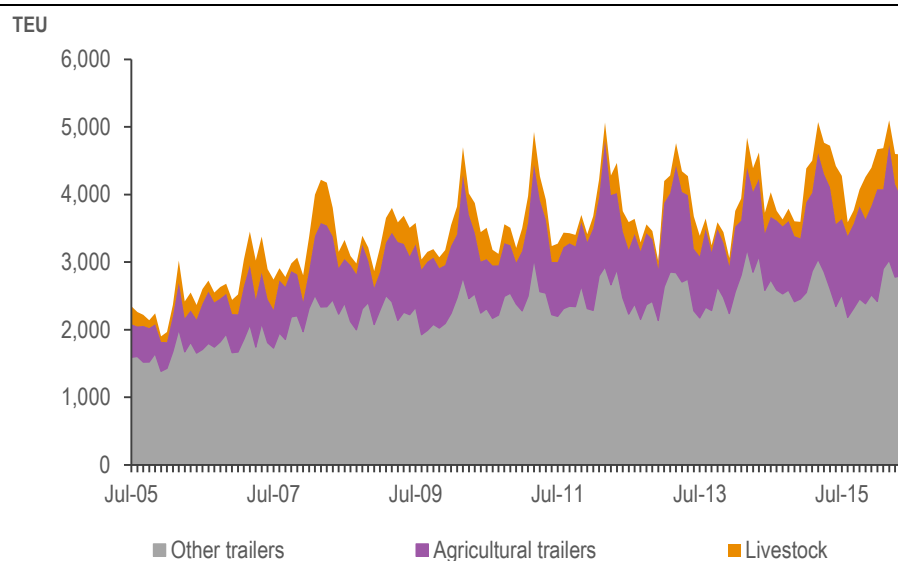
FIGURE 4.2 TRAILER FREIGHT - TRADE WITH PORT OF MELBOURNE BY PRODUCT CATEGORY

SOURCE: PORT OF MELBOURNE

Between 2006 and 2015, the volume of non-agricultural (other) trailers increased from 21,000 TEU to 31,000 TEU per year. This translates to an annual compound growth rate of about 4.3 per cent. While demand for this type of freight is far less seasonal than that of agricultural trailers, a peak between February and April is observable. The constraints analysis assumes that the other trailer demand continues its recent growth and that the seasonal pattern remains unchanged.

Livestock is a high volume agricultural export, which has similar characteristics to time sensitive freight. There is some overlap in the freight services used. Livestock has been separately analysed to understand its impact on available capacity for the time sensitive freight market. Livestock transports have fluctuated around a moderate upwards trend over the study period. In fact, without the extraordinarily high demand that occurred in 2015, the trend over the study period would be a slight demand contraction. The 2015 turn-off is generally expected to be unsustainable as current trade is being driven by historically high cattle prices (Department of Primary Industries, Parks, Water and Environment and Department of State Growth, 2016).

The constraints analysis below therefore assumes a base trailerised freight demand of 3,800 TEU for 2016-17 which is slightly above the historic average. The producer aspiration scenario assumes steady growth reaching the 2015 level by 2020-21. Seasonality is assumed to remain unchanged with a distinct peak between February and June and a trough in August to December.

Figure 4.3 presents the historic and projected monthly trailer export demand by product category from 2005 to 2021. The figure shows that the modelled trailer demand aligns with the Port of Melbourne data¹ and that peak demand is expected to grow from current levels of about 5,000 TEU to about 7,500 TEU at the peak at the end of the study period under the producer aspiration scenario. Most of the growth is expected to occur in the agricultural product category.

The trailer demand projection can now be compared to the capacity of the three vessels.

¹ It only shows slightly more pronounced seasonality which, since this could be a reaction of the market to seasonal capacity constraints, is not considered a misalignment.

FIGURE 4.3 TRAILER FREIGHT – MONTHLY EXPORT DEMAND BY PRODUCT GROUP, PRODUCER ASPIRATION GROWTH, 2005 TO 2021

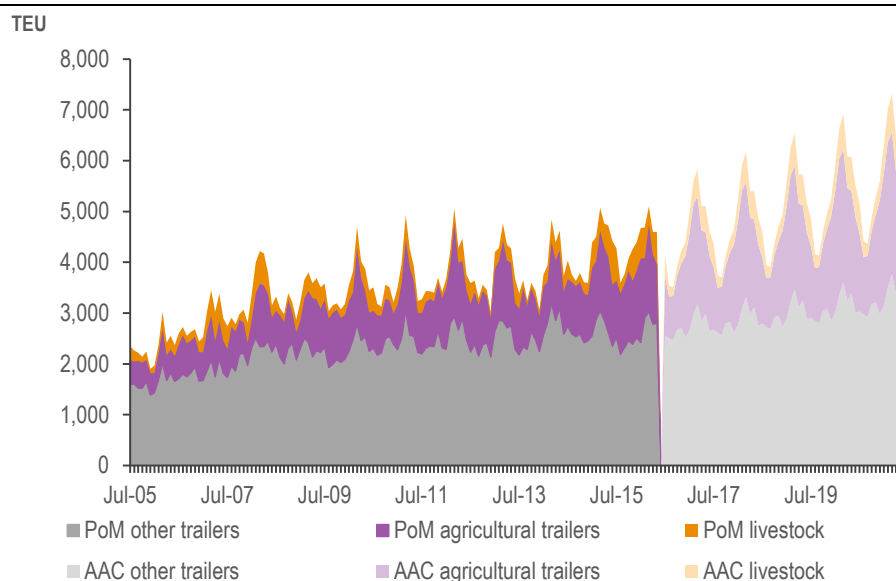

SOURCE: ACIL ALLEN ANALYSIS OF TASMANIAN INDUSTRY (INTERVIEWS WITH ACIL ALLEN, 2016) AND PORT OF MELBOURNE DATA

4.4 Trailer freight – analysis of time sensitive freight capacity

The next two sections analyse future demand relative to capacity for trailer and container freight respectively. For confidentiality reasons, ACIL-Allen was unable to access detailed data on market share by operator, or the volume of individual commodities carried by each operator. For this reason, current market shares (both base demand and for agricultural products) have been estimated at a high level.

The scenarios also consider the potential impact of future vessel replacement plans on future market shares.

The monthly demand presented above was converted into daily demand by evenly distributing each grower's production across the relevant month, and assuming products leave a processing site once a trailer is filled.

For example, if a trailer can hold 21 tonnes of a certain product and a grower produces seven tonnes a day, then the model predicts that one trailer leaves the processing site every three days. This approach continues the idea of a stress test as it concentrates demand because it does not allow the growers to send off mixed trailers.

As with the other two operators, TT-Line caters for the "base demand" for transporting non-seasonal freight across the Bass Strait. This analytical framework assumes that base (non-seasonal) demand is allocated the required spots before the (far more seasonal) agriculture products.

TT-Line's most recent annual report suggests that an average of 125 TEUs is carried per sailing. This is higher during peak periods. Taking into account the demand for agricultural products, TT-Line has been modelled to capture about 85 per cent of base trailerised demand into and out of Devonport.

The remaining base demand for trailerised freight has been allocated as 5 per cent on SeaRoad (excluding livestock) and 10 per cent on Toll.

Based on consultation with freight forwarders for trailers, the current preferred hierarchy of shipping services is to use TT-Line, followed by SeaRoad and Toll. If more than one service is used on any given day, freight is allocated based on its time sensitivity, with the most time sensitive products moved via TT-Line in order to maximise remaining shelf life (Tasmanian industry, 2016).

The trailer capacity of Toll's new vessels, which are due to be operational by mid-2019, is unknown. For this reason, and reflecting a clear preference for time sensitive freight to be moved via TT-Line and then SeaRoad, ACIL-Allen has modelled trailer capacity using the following steps:

1. Base demand is allocated the spots it requires on the day on the relevant vessel
2. Trailers with agricultural (time sensitive) products are allocated the remaining spots on TT-Line
3. If TT-Line demand exceeds its capacity, the remaining trailers move to SeaRoad

Filling TT-Line to capacity before demand is allocated to any other vessel likely overestimates TT-Line demand. However, given data limitations and stated preferences, this simplification appears reasonable, and the resulting analysis has been undertaken to provide an indication of the thresholds at which capacity bottlenecks may arise.

Figure 4.4 presents the resulting (modelled) demand for TT-Line and SeaRoad in relation to agricultural commodities. It also shows potential excess demand for each service according to the preference system described above. Note that the modelling only considers the capacity of the new SeaRoad vessels. The expected introduction of the second new SeaRoad vessel in January 2019 will see increased daily capacity for SeaRoad, and this can be seen in the more intense colours in the figure after that date.

The figure is consistent with the opinion expressed by stakeholders consulted by ACIL Allen that in recent years there has been a shortfall of capacity on TT Line for transporting time sensitive freight and customer induced time sensitive freight across the Bass Strait at peak times, due to a distinct preference for the TT ferries over the old SeaRoad vessels.

Figure 4.4 shows that the excess demand for the TT ferries would persist in the future in the *unlikely* case that the new SeaRoad vessels (the first already operational and the second expected to be operational in early 2019) are unable to attract any spillover demand that cannot be met by TT-Line.

FIGURE 4.4 TRAILER FREIGHT - CONSTRAINED DEMAND BY TYPE AND OPERATOR, PRODUCER ASPIRATION GROWTH

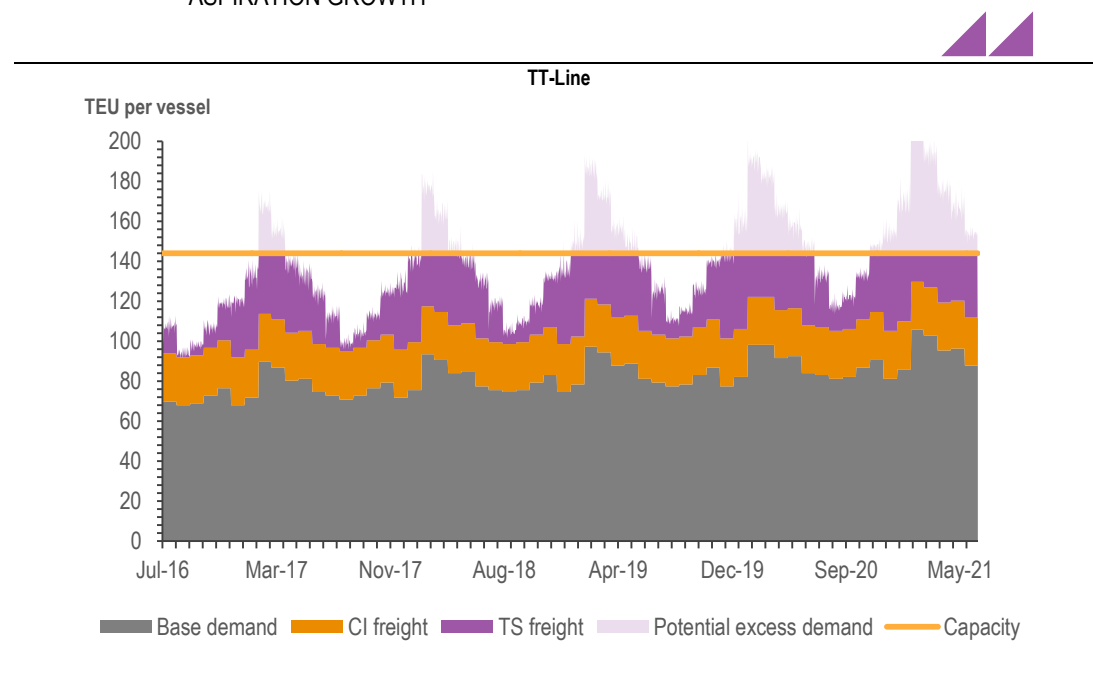

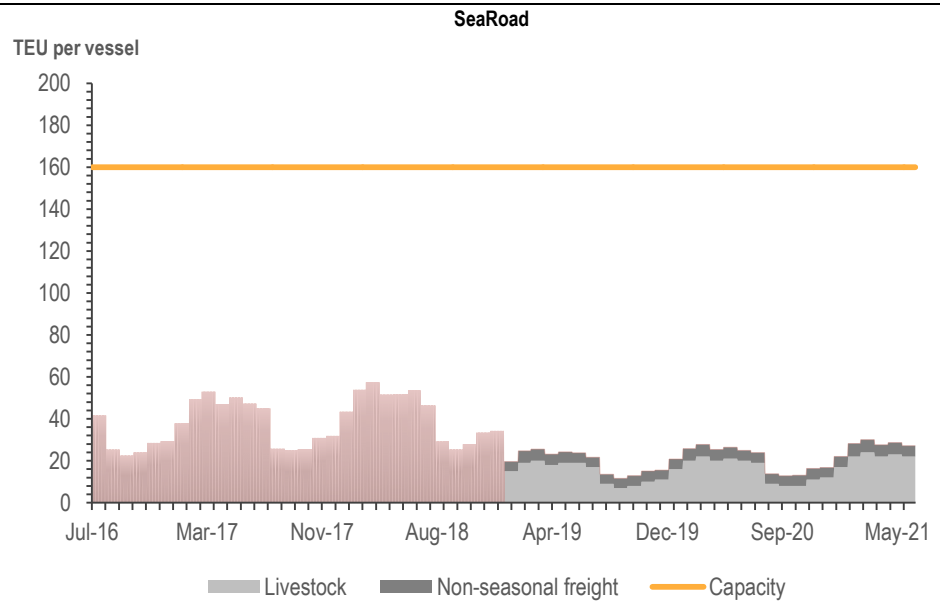

SOURCE: ACIL ALLEN MODELLING

Figure 4.5 illustrates the *more plausible scenario* where the new SeaRoad vessels capture higher volumes of both base demand and agricultural freight. The figure shows that while TT-Line is unlikely to be able to handle peak demand by itself during the forecast period, SeaRoad is able to absorb much higher levels of excess demand and will have even greater capacity with the introduction of its second replacement vessel.

FIGURE 4.5 TRAILER FREIGHT - CONSTRAINED DEMAND BY TYPE AND OPERATOR, PRODUCER ASPIRATION GROWTH

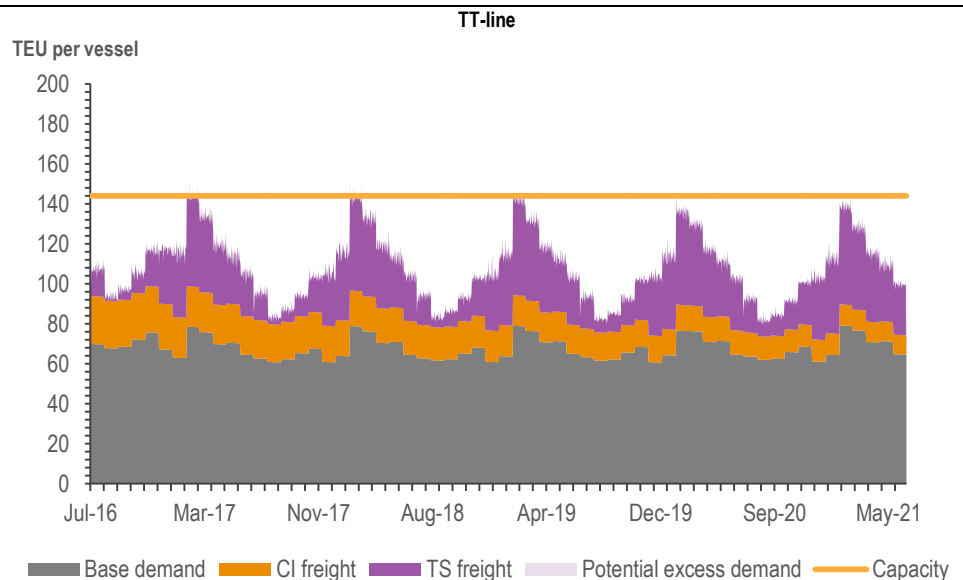

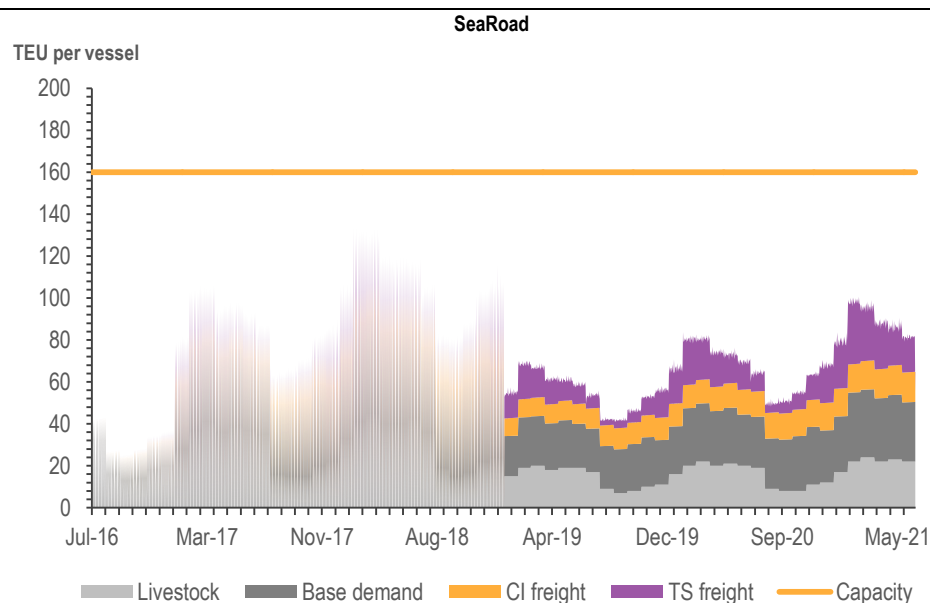

SOURCE: ACIL ALLEN MODELLING

This scenario assumes:

- with the introduction of the new vessel, SeaRoad will capture an additional 10 per cent of all three freight types (base demand, time sensitive freight (TS) and freight with customer induced time sensitivity (CI)). Actual demand could be higher or lower across market segments.²
- demand for TT-Line remains stable after this, which means that SeaRoad will capture any additional freight demand
- SeaRoad remains the main transporter of livestock.

Under these assumptions, both operators could cater for demand at any point of the study period and that, even under the grower aspiration scenario, SeaRoad still has spare capacity at the end of the study period.

While not modelled, Toll intends to enhance trailer capacity as part of its own vessel replacement plans, further increasing overall capacity across the three shipping lines.

4.5 Container freight – analysis of demand and capacity

ACIL Allen also analysed container demand in the time sensitive freight market.

Based on the supply chain assumptions used in this study, at least a share of the production of six of the 28 analysed product types crosses Bass Strait in a container (see Figure 4.2). All products transported in containers are in the market segment with customer induced time sensitivity.

Figure 4.6 shows the projected (unconstrained) monthly demand for containerised freight across Bass Strait by product type. The figure demonstrates that demand is subject to a distinct seasonal pattern. In the base year, demand is about 1,600 TEU in the trough and about 2,600 TEU in the peak month. Forecast growth is moderate, with peak demand below 2,800 TEU at the end of the forecast period.

² SeaRoad has to capture a minimum of eight per cent of all three freight types in order to avoid excess demand on TT-Line during the 2017 peak export season.

FIGURE 4.6 CONTAINER FREIGHT - DEMAND PROJECTION, PRODUCER ASPIRATION GROWTH SCENARIO

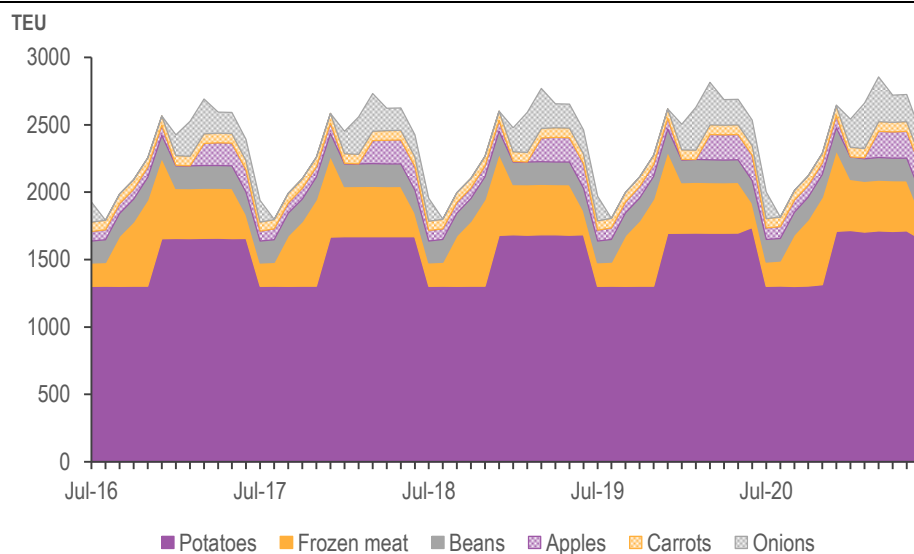

SOURCE: ACIL ALLEN ANALYSIS OF TASMANIAN INDUSTRY DATA (INTERVIEWS WITH ACIL ALLEN, 2016)

Figure 4.7 presents the historical and projected monthly container export demand by product category from 2005 to 2021. The figure shows that container demand is expected to remain relatively stable.

FIGURE 4.7 CONTAINER FREIGHT - MONTHLY EXPORT DEMAND BY PRODUCT GROUP AND GROWTH SCENARIO, 2005 TO 2021

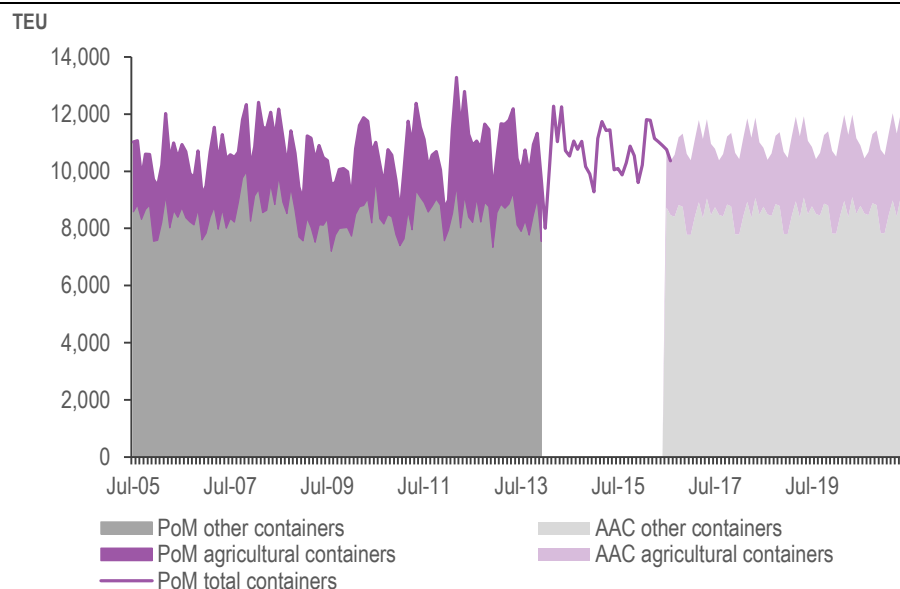

To address a change in product classification affecting base demand (increase) and agricultural containers (decrease) in January 2014, forecasts are based on 2013 figures. For the period between the end of 2013 and the start of the forecast period (white gap in the figure), only total demand is presented.

The export demand forecast also assumes that the other container demand (for non-time sensitive products) continues its recent growth and that the seasonal pattern remains unchanged.

SOURCE: PORT OF MELBOURNE AND ACIL ALLEN ANALYSIS OF TASMANIAN INDUSTRY DATA (INTERVIEWS WITH ACIL ALLEN, 2016)

Monthly demand forecasts were converted into daily demand by evenly distributing each grower’s production across the relevant month and assuming that products leave the processing site once a container is filled.

For example, if a container can hold 12 tonnes of a certain product and a grower produces six tonnes a day, then the model predicts that one trailer leaves the processing site every two days. This approach continues the idea of a stress test, as it concentrates demand because it does not allow the growers to send off mixed containers.

Toll is the major container operator, and carries the highest volume of agricultural containers. Capacity allocation was modelled using the following steps:

1. Base demand is allocated the spots it requires on the day on the relevant vessel
2. Containers with agriculture products are allocated the remaining spots on Toll
3. If Toll demand exceeds its capacity, remaining containers are moved to SeaRoad.

The analysis includes new vessels for Toll.

Figure 4.8 presents the modelled demand for Toll. The figure shows that even under the producer aspiration scenario, container capacity is expected to be sufficient at every point of time in the study period.

All containerised agricultural products can be carried on the Toll ferries, SeaRoad's container capacity has not been included in the analysis.

FIGURE 4.8 CONTAINER FREIGHT - CONSTRAINED DEMAND BY TYPE AND FERRY, HIGH GROWTH

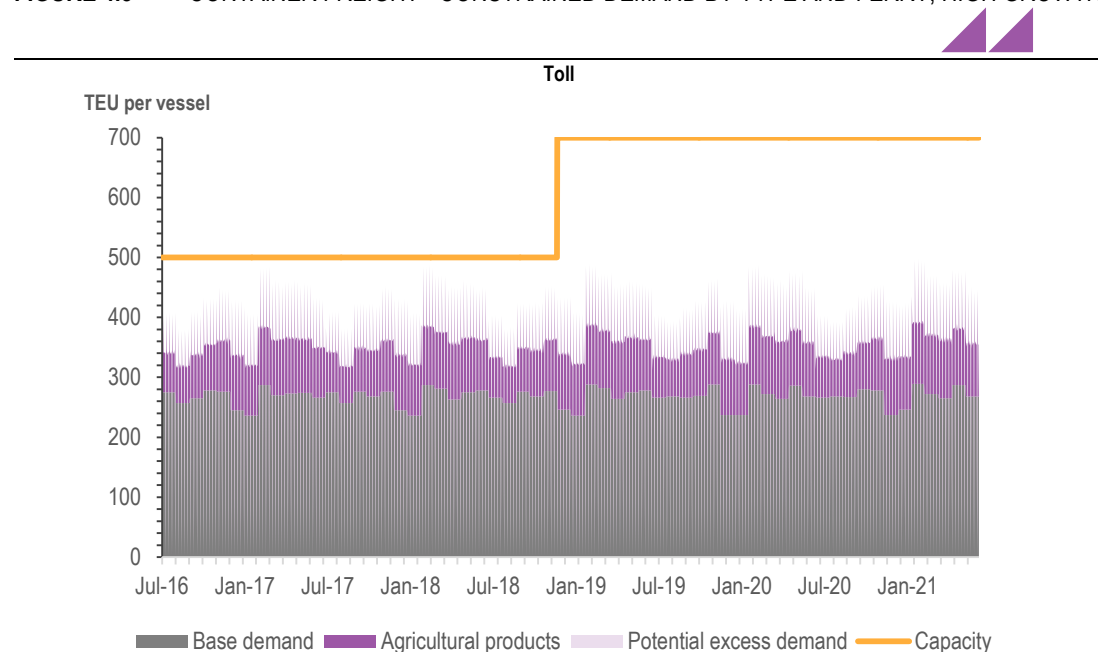

SOURCE: ACIL ALLEN MODELLING

5

AIR FREIGHT

This chapter analyses air freight demand and capacity across Bass Strait, focusing on the highly time sensitive freight market.

5.1 Overview

Air freight can be transported in passenger planes or dedicated freight planes. When transported in passenger planes, issues could arise around the prioritisation of freight versus luggage, with potential impacts on the quality of freight service and transit times.

Regardless of plane type, air freight is transported in unit load devices (ULDs), designed to allow fast and efficient handling whilst making maximum use of available space. While there is a wide variety of ULDs, consultation found that the two ULDs presented in Table 5.1 are most frequently used (Tasmanian industry, 2016).

TABLE 5.1 AIR FREIGHT - MAIN TYPES OF UNIT LOAD DEVICES

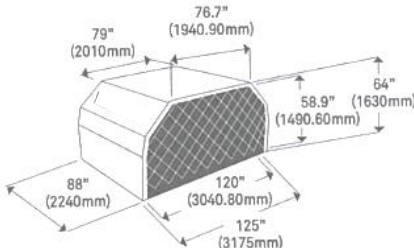
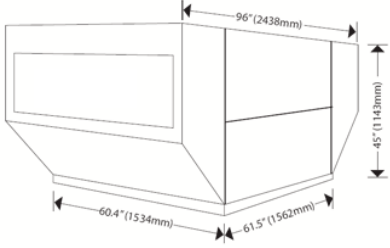
	Freight ULD	Small ULD
		
Aircraft types	B747, B767, B787, A330, A380	A320
Internal volume	9.8 m ³	3.7 m ³
Load capacity	5,800 kg	920 kg
Capacity per plane	17 (B747)	3

SOURCE: COMPANY REPORTS AND TASMANIAN INDUSTRY (INTERVIEWS WITH ACIL ALLEN, 2016)

Since airlines try to minimise the time a plane spends on the ground, air freight is usually aggregated close to or at an airport so it is ready for loading when the plane arrives. This often requires producers to set up a dedicated (optimised) air freight supply chain that is typically less flexible than one that relies on trailers or containers.

The vast majority of Tasmanian products must currently travel to the Australian mainland via sea or on domestic flights before being air freighted to their final destination. This system results in multiple

handling and associated time delays which result from the time required to load and unload products, and the logistics required to co-ordinate the arrival and departure of products.

Air freight is attractive to producers that require very fast transport of their goods. With typical freight rates of between \$2 and \$3 per kg from Tasmania to international markets, it is comparatively expensive and therefore only a viable option for high value products. Air freight out of Melbourne is an attractive option for products with a shelf life of one week or more.

The exception is the recently announced dedicated freight service from Hobart to Ningbo in China operated by Van Diemen's Land Farms (VDL). It is expected to commence operation in early 2017 and after a ramp up phase export approximately 10 million litres of fresh milk a year via three or four flights per week.

5.2 Key routes

Hobart and Launceston airports support air freight services. Most freight is carried on passenger planes operated by Qantas, Jetstar, Virgin and Tiger Air. Together these airlines operate between 15 and 20 flights a day between Tasmania and the mainland (predominantly Melbourne). These flights typically use narrow body aircraft such as Airbus A320 or Boeing 717.

Virgin currently operates a Boeing 737 freighter service from Launceston to Melbourne (and on to Perth) four nights per week, while Qantas operates a B737 freighter service from Hobart and Launceston to Melbourne and Sydney four nights per week.

As of early 2017 there are three possible routes for international air freight out of Tasmania. These are via sea with transfer to Melbourne airport; via air to Melbourne or Sydney airports; or direct to Ningbo in China.

Apart from the VDL flight discussed above, there are no direct international flights departing from Tasmania at this stage. Instead, products fly to Melbourne where they are transferred to domestic or international flights. While this arrangement results in double handling, Melbourne offers connections to a large number of international destinations and a level of export market flexibility that a Tasmanian airport is very unlikely to achieve.

Feedback from stakeholders has indicated a range of experiences with air freight services out of Melbourne Airport. This includes obstacles encountered when using trailers, where products have been left behind in Melbourne resulting in significant revenue reductions.

5.3 Demand for air freight

Based on the supply chain assumptions used in this report, at least a share of the production of 10 of the 28 analysed product types crosses Bass Strait by air. Table 5.2 presents these 10 products, their market segment and the price risk score.

TABLE 5.2 AIR FREIGHT – PRODUCT TYPES

Market segment	Product type	Price score	Airport
Time sensitive	Cherries	2	Melbourne
Time sensitive	Salmon	3	Melbourne
Customer induced	Broccoli	5	Melbourne
Customer induced	Cheese	5	Melbourne
Time sensitive	Milk	5	Hobart
Highly time sensitive	Abalone	1	Hobart
Highly time sensitive	Lobster	1	Hobart
Time sensitive	Mussels	4	Hobart
Time sensitive	Oysters	3	Hobart

Market segment	Product type	Price score	Airport
Customer induced	Poppies	NA	Launceston

SOURCE: ACIL ALLEN ANALYSIS OF TASMANIAN INDUSTRY DATA (INTERVIEWS WITH ACIL ALLEN, 2016)

A price risk score of one or two makes a product a likely candidate for air freight, a score of three a possible candidate and scores of four and five, an unlikely one. The table above shows products with risk scores of four or five are air freighted. This apparent contradiction to the logic presented above, can be resolved when considering that the prices used on the risk assessment are average export prices and only small batches with particular characteristics of the products in question use air freight. These batches may be destined for niche markets with significant price premiums for greater speed to market.

Specifically, only about 20 per cent of the mussel production is transported as air freight and the price risk assessment is based on an average export price of \$8.30 per kg which is at the upper end. Prices of non-bulk high value agricultural products can differ substantially depending on the quality of the individual item.

For example, wholesale export prices for Tasmanian cherries range between \$13 and \$30 per kg depending on their size with an average price of \$17 per kg (Department of Primary Industries, Parks, Water and Environment and Department of State Growth, 2016). Considering this range, it is not unreasonable to expect that the highest quality fifth of mussels fetches a significantly above average price which would result in a price risk score of three (\$10 per kg or more) or even of two (\$15 per kg or more). A similar logic can be applied cheese and to a degree to milk as well as a producer directly exports a very small share of the production to a very specific market.

Industry stated that under certain conditions (e.g. if there are localised supply shortages) some semi-bulk lower value products such as broccoli can fetch far above average prices for a limited time (Tasmanian industry, 2016). Since these local price spikes are difficult to predict and demand is restricted the general statement that these products are unlikely candidates for air freight still holds. This observation highlights however the high flexibility of the trailer bound supply chains, because the decision about the final destination can be made very late in the supply chain.

Figure 5.1 presents the projected (unconstrained) monthly demand for air freight that uses passenger planes from Hobart (top chart) and air freight that uses freight planes from Melbourne or (in case of fresh milk) Hobart (bottom chart). The figure demonstrates that demand in Hobart is subject to a distinct seasonal pattern. In the base year, demand is about 200 small ULD in trough and up to 1,400 small ULD in the peak month. Since this freight group is dominated by seafood that is subject to catch restrictions, growth is very limited.

The freight plane bound products show a far less pronounced seasonal pattern. In fact fresh milk, cheese, broccoli and salmon exports are subject to hardly any seasonal fluctuations. Cherries in contrast are only exported in three months of the year. Under the presented scenario this freight group is expected to experience strong growth in salmon and cherry exports lifting trough demand from 500 freight ULD to 600 freight ULD and peak demand from just under 800 freight ULD per month to over 1,000 freight ULD per month.

FIGURE 5.1 AIR FREIGHT – DEMAND PROJECTION, PRODUCER ASPIRATION GROWTH SCENARIO

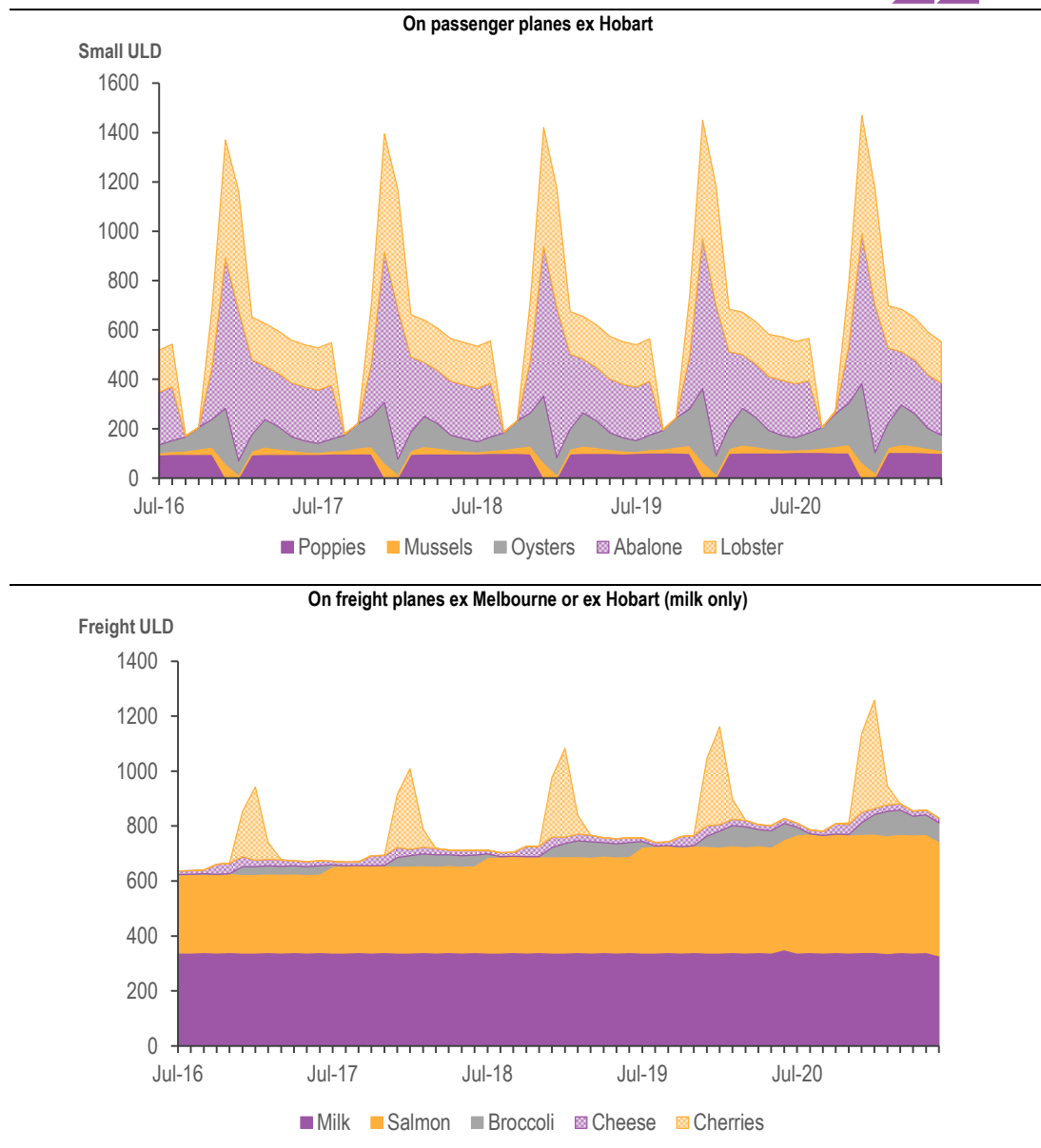

SOURCE: ACIL ALLEN ANALYSIS OF TASMANIAN INDUSTRY DATA (INTERVIEWS WITH ACIL ALLEN, 2016)

5.4 Constraints

As mentioned above, VDL is expected to relatively quickly ramp up to three or four flights per week using a Boeing 767 freighter aircraft. This means that the 10,000 tonnes expected to be exported per year will be spread over 156 flights per year. As each has a capacity of about 5.8 tonnes, this indicates that each plane will carry 11 or 12 freight ULDs of milk. This leaves a likely spare capacity of five to six freight ULDs per flight.

There are at least 15 daily passenger flights from Tasmania to Melbourne of which the majority uses A320 aircrafts with a capacity of three small ULDs. This translates to a total daily capacity of approximately 45 small ULD. The capacity of Melbourne Airport was not estimated but can be assumed to substantially exceed that of Hobart Airport.

With no significant growth in air freight expected over the next five years, Figure 5.2 demonstrates that the three routes are unlikely to experience capacity constraints. The extreme seasonality of both

series is striking however. Demand for these routes is relatively stable at around 10 (small ex Hobart and freight ex Melbourne) ULD per day but triples to 30 during the January peak

FIGURE 5.2 AIR FREIGHT - CONSTRAINED DEMAND BY PLANE TYPE, HIGH GROWTH

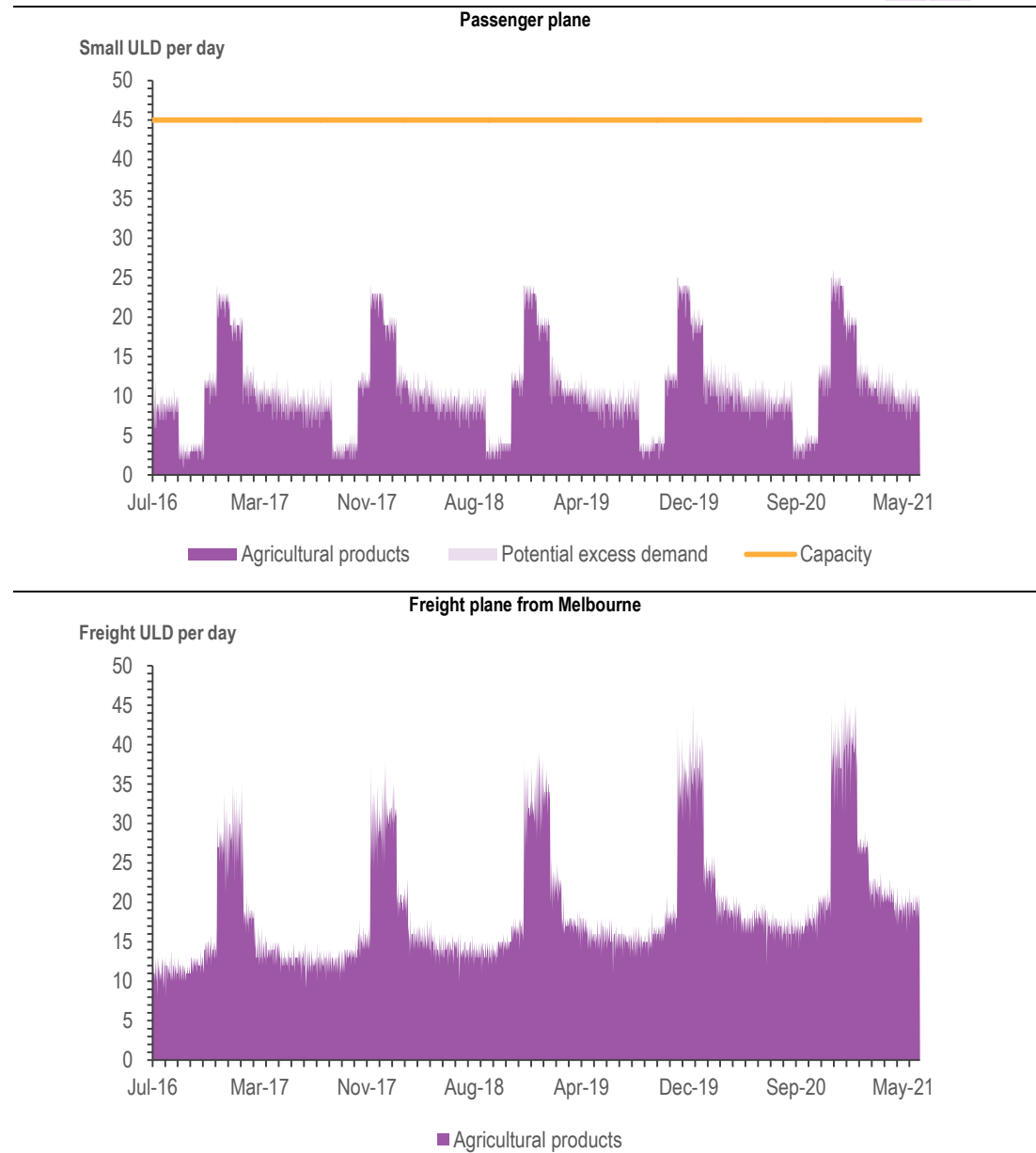

SOURCE: ACIL ALLEN MODELLING



This chapter provides general advice on a repeatable methodology to collect time sensitive freight data in Tasmania.

6.1 Data Sources

There is currently no comprehensive data set accurately describing the time sensitive freight market in Tasmania. For this study, ACIL Allen explored a number of data sources in order to develop a market and commodity database. In identifying the most useful data, the following criteria were applied:

- **Market representation:** the data collected accurately represents all or the vast majority of the market
- **Confidentiality:** recognition of the confidentiality of operating data of some organisations and industries
- **Data availability:** the availability of accurate data held by government and others such as industry bodies
- **Efficiency:** the ease of collection in terms of the time and labour resources for the collector of information and the survey respondent.

The primary source of data for describing the time sensitive freight market in Tasmania should be existing data sets that are compiled from actual industry data. This includes data held by the Australian and Tasmanian Governments, both of which hold significant industry-derived datasets, and peak industry bodies.

The ABS undertakes an agricultural census every five years, which provides base data across all commodities surveyed within this report.

In Tasmania, DPIPWE is a very good source of agricultural data, derived from its Industry Scorecard, regulatory responsibilities and general industry consultation. The Tasmanian Freight Survey is a useful source of data for higher volume, bulk commodities, largely in the customer-induced market segment. The Agri-business section of the Department of State Growth holds data and information on specific industry sectors, including fresh and frozen meat, and berries, as well as access to some industry information in relation to exported product including fresh and frozen meat.

Key peak bodies include DairyTas, Dairy Australia, Tasmanian Fruit Growers, Cherry Growers Australia, Apples and Pears Australia Limited, Tasmanian Seafood Industry Council, Oysters Tasmania and the Tasmanian Rock Lobster Fishermen's Association.

In order of preference, the key data sources are:

- Collection of data for regulated industries, from Government and/or publically available, such as for scallops, oysters, abalone and rock lobsters. These data sources should include DPIPWE's Sea Fishing and Aquaculture branch.

Collection of other data held by Government -The ABS:

- undertakes an Agricultural Census every five years, which provides production data.
- publishes annual production data for meat and livestock.
- collects annual unpublished trade data which provides information on export prices and export volumes.

The Tasmanian Government collects data:

- as part of its Industry Scorecard and Tasmanian Freight Survey.
- on an ad hoc basis through regular industry consultation.
- Collection of data from peak industry bodies.
- Collection of remaining data through a survey targeted at specific processors and producers.

6.1.1 Volume of annual production

Very few products have reliable, published data on annual production volumes.

The DPIPWE Sea Fishing and Aquaculture branch holds reliable month by month production volumes for managed fisheries (abalone, lobster, scallops and oysters). The branch also holds unpublished annual production data for the wild catch and aquaculture seafood products (mussels and salmon).

For dairy products such as milk and cheese production, DairyTas and Dairy Australia produce annual reports that provide information on production volumes of dairy products.

The ABS conducts an Agricultural Census every five years, with the last Census held in 2010-11. This Census collects detailed agricultural data from businesses across a variety of industries. The Census includes land use and production data for all time sensitive products except fisheries, dairy, poppies and cut flowers (data is only collected on area under production).

In interim years, the ABS estimates annual production volumes with a relatively high standard error of up to 50 per cent ((Australian Bureau of Statistics, 2015)). In these years, data should be sourced from published data held by industry bodies and, where this is not available, via a survey of industry bodies and key processors and producers (e.g. Fruit Growers Tasmania, Apples and Pears Australia).

6.1.2 Price

This study used export price data. The key source of this data was unpublished ABS trade data, which is available for all time sensitive products, with the following key exceptions:

- Salads – while the price of lettuce was used as a proxy, it is noted that prices vary significantly based on product type and level of value add
- Raspberries, blueberries, strawberries and blackberries – again, while the price of frozen berries was used as a proxy, it is noted that there is a significant difference in the price of frozen versus fresh berries, and between different berry types.

6.1.3 Volume by market destination

Market production was categorised by production for the local Tasmanian market, the Australian mainland market and the overseas market. There is very little published data available to make this differentiation. The following data sources are recommended:

- International export volumes – unpublished volumes are available from the ABS for all commodities except milk, salads, raspberries, strawberries, blueberries, blackberries, poppies, carrots, beans and potatoes. For milk, data is available from DairyTas and Dairy Australia. For all other commodities, a survey of key processors and producers is recommended.
- Australian mainland volumes – this study used data from the Port of Melbourne to calculate the majority of trade with the Australian mainland by comparing this with export data. If Port of Melbourne data is not available, trade volumes with the Australian mainland would need to be estimated via survey. Information on dairy products can be sourced from DairyTas.
- Tasmanian volumes – via survey. Information on dairy products can be sourced from DairyTas, and for apples from Fruit Growers Tasmania.

6.1.4 Future industry growth

For the regulated industries, future growth is controlled by regulation and is available from DPIPWE. For all other products, future growth is determined by individual producers and processors and should be collected via survey.

In conducting its survey for this study, ACIL Allen found that the reliability of future production estimates, varied, reflecting the difficulties of forecasting in this sector. It is recommended that this type of information is collected on an infrequent survey basis and/or derived from historic production once a longitudinal dataset is developed. Growth rates could also be calculated by comparing longitudinal ABS Census data and cross referencing this with data collected through surveys.

6.2 Summary of methodology and recommendations

The future methodology for collecting data regarding the time sensitive freight market should include the development and maintenance of an annually-updated database addressing production volumes, price and market destination. Sources of data will vary by year.

Specifically, a future methodology should include:

- Regular collection of available data from key, primary sources.
- Primary data sources include DPIPWE, the ABS, data produced by DairyTas, Dairy Australia, Tasmanian Fruit Growers, Apples and Pears Australia Limited, the Tasmanian Seafood Industry Council, and other peak industry bodies.
- Gap analysis to identify missing data, with collection of missing data via survey.
- Data should be collected for all industries but emphasis should be placed on those industries for which there is little data or known data gaps. These include berries, other stone fruit, potato, carrots and beans.
- An industry survey should be undertaken to supplement the above data sources. The survey should be undertaken to coincide with the Tasmanian Freight Survey (every three years), and as close as possible to publication of the ABS Agricultural Census (every five years).
- Cross-referencing of all survey data with current and historical data.

Alternatively, the Department may want to consider developing an annual database of the Tasmania time sensitive freight market through the collection of ABS data only.



REFERENCES

- ABARES. (2016). *Agriculture, Fisheries and Forestry in Tasmania*. Canberra: Government of Australia.
- ACIL Allen Consulting. (2016). *Burnie to Hobart Freight Corridor Strategy: Freight demand analysis*. unpublished.
- Aurecon for Department of Infrastructure, Energy and Resources. (2013). *Freight Logistics Coordination Team Major Consultancy Support to Work Program: Supply Chains in Tasmania*. Hobart: Department of Infrastructure, Energy and Resources.
- Aussie Apples. (2016, September 09). *Aussie Apples*. Retrieved from Aussie Apples: <http://www.aussieapples.com.au/growing-regions/tasmania.aspx>
- Australian Bureau of Agricultural and Resource Economics and Sciences. (2015). *Australian fisheries and aquaculture statistics*.
- Australian Bureau of Statistics. (2014-15). *Catalogue 7121: Agricultural Commodities, Australia*.
- Australian Bureau of Statistics. (2015). *Agricultural Commodities, Australia, 2014-15: Catalogue 7121.0*. Canberra: Government of Australia.
- Cherry Growers Association. (2016, September 3). *Cherry Growers Association*. Retrieved from <http://www.cherrygrowers.org.au/>
- DairyTas. (2016). *Tasmania's dairy regions*.
- Department of Primary Industries, Parks, Water and Environment. (2014). *Potato Market Profile*. Hobart: Government of Tasmania.
- Department of Primary Industries, Parks, Water and Environment. (2016, September 07). *Rock Lobster Catch Updates*. Retrieved from Department of Primary Industries, Parks, Water and Environment: <http://dpipwe.tas.gov.au/sea-fishing-aquaculture/commercial-fishing/rock-lobster-fishery/rock-lobster-catch>
- Department of Primary Industries, Parks, Water and Environment and Department of State Growth. (2016). *Internal data*.
- Department of State Growth. (2015). *Container growth and capacity, Bass Strait*.
- Department of State Growth. (2016). *Tasmanian Freight Survey 2014-15*.
- Department of State Growth. (various). *Tasmanian Freight Survey*. Hobart: Department of State Growth.
- Fruit Growers Tasmania. (2016, September 1). *Fruit Growers Tasmania*. Retrieved from Fruit Growers Tasmania: <http://www.fruitgrowerstas.com.au>

- Oysters Tasmania. (2016, September 5). Retrieved from Oysters Tasmania:
<http://oysterstasmania.org/>
- Port of Melbourne. (2016). *Container and trailer trade between Port of Melbourne and Bass Strait (unpublished data)*.
- Spring Bay Seafoods. (2016, September 08). *Spring Bay Seafoods*. Retrieved from Spring Bay Seafoods: <http://www.springbayseafoods.com.au>
- Tasmanian Abalone Council. (2016, September 3). *Tasmanian Abalone Council*. Retrieved from Tasmanian Abalone Council: <http://tasabalone.com.au>
- Tasmanian Fruit and Vegetable Industry Taskforce. (2014). *A growth plan for the Tasmanian fruit and vegetable industries*. Tasmanian Fruit and Vegetable Industry Taskforce.
- Tasmanian industry. (2016). *Interviews with ACIL Allen*.
- Tasmanian Rock Lobster Fishermen's Association. (2016, September 07). Retrieved from Tasmanian Rock Lobster Fishermen's Association: <http://www.tasrocklobster.com>
- Tasmanian Seafood Industry Council. (2011). *The Tasmanian Seafood Industry*. Hobart: Tasmanian Seafood Industry Council.
- Tasmanian Seafood Industry Council. (2016, September 07). *An overview of the Scallop Industry*. Retrieved from Tasmanian Seafood Industry Council:
http://www.tsic.org.au/files/Industry_Profile/sector_profiles/Scallop_Profile2.pdf
- Vegetable Industry Development Program. (n.d.). *Vegetable production in Tasmania*.

ACIL ALLEN CONSULTING PTY LTD
ABN 68 102 652 148
ACILALLEN.COM.AU

ABOUT ACIL ALLEN CONSULTING

ACIL ALLEN CONSULTING IS ONE OF
THE LARGEST INDEPENDENT,
ECONOMIC, PUBLIC POLICY, AND
PUBLIC AFFAIRS MANAGEMENT
CONSULTING FIRMS IN AUSTRALIA.

WE ADVISE COMPANIES,
INSTITUTIONS AND GOVERNMENTS
ON ECONOMICS, POLICY AND
CORPORATE PUBLIC AFFAIRS
MANAGEMENT.

WE PROVIDE SENIOR ADVISORY
SERVICES THAT BRING
UNPARALLELED STRATEGIC
THINKING AND REAL WORLD
EXPERIENCE TO BEAR ON PROBLEM
SOLVING AND STRATEGY
FORMULATION.

